

EVOPLUS SMALL / EVOPLUS SMALL SAN

WET ROTOR ELECTRONIC CIRCULATORS



in line with European Directive
ErP 2009/125/EC (formerly EuP) of 2015

TECHNICAL DATA

Operating range: from 2 a 12 m³/h with head of up to 11 metres.

Pumped liquid temperature range: from -10 °C to +110 °C.

Pumped liquid: clean, free of solids and mineral oils, non-viscous, chemically neutral, with properties similar to water. (glycol max 30%).

Maximum operating pressure: 16 bar (1600 kPa).

Standard flanges: DN 32, DN 40 PN 6 / PN 10 / PN 16 (4 holes).

Maximum ambient temperature: + 40 °C.

Minimum suction pressure: the values are shown in the corresponding tables.

Accessories: ½" F, ¾" F, 1" F, 1" ¼ F, 1" ¼ M union connectors.

Electromagnetic compatibility: EVOPLUS circulator comply with EN 61800-3 standard, category C2, as far as electromagnetic compatibility.

Electromagnetic emissions: Residential environment (containment measures might be required in some cases).

Conducted emissions: Residential environment (containment measures might be required in some cases).

Circulator protection class: IP 44.

Insulation class: F.

Standard voltage: single-phase 220-240 V, 50/60 Hz.

Sound pressure values: ≤ 33 dB(A).

Product compliant with European Standards EN 61800-3 – EN 60335-1 – EN 60335-2-51

APPLICATIONS

EVOPLUS circulation electronic pumps can be used in heating, ventilation, and air conditioning systems for residential and commercial buildings, like:

- Large residential buildings
- Condominiums and small apartment buildings
- Homes
- Real estate buildings
- Private and public hospitals
- Schools
- Office buildings

Single version available, with 1 ½" e 2" threaded ports, and with DN 32 and DN 40, PN 6 / PN 10 / PN 16 flanged ports.

Twin version available with DN 32 and DN 40, PN 6 / PN 10 / PN 16 flanged pump body.

Special version available with bronze pump body for the recirculation of sanitary water.

Possibility of 0-10 V or PWM external signal control, and connection to ModBus management systems (LonBus with appropriate additional communication module), with the use of the optional Multifunction module (supplied as standard for the twin version).

HEATING SYSTEM APPLICATIONS

The heating required for the different applications varies significantly during day and night, due to the external temperature, or the degree of occupancy inside the areas. To the above, one must add the different needs of the various environments, and the opening or closing of the various circuit branches of complex systems. Electronic wet rotor pumps ensure at all times, and virtually in all correctly sized systems, a sufficient level of energy, together with a quieter operation, and more comfort, together with an important reduction of operating costs.

AIR CONDITIONING APPLICATIONS

Unlike conventional electronic pumps, EVOPLUS electronic circulators can be used also in air conditioning systems where the temperature of the pumped liquid is lower than the room temperature. In these conditions, condensation tends to form on the outer surface of the circulator, which however does not affect the operation of the electronic and the mechanical components. The unit is designed and sized in such a way that it allows condensation to drain without damage to the construction components.

SANITARY RECIRCULATION APPLICATIONS

The SAN version, with bronze pump body, was specifically developed for the recirculation of sanitary water. With the constant temperature mode of operation, the temperature inside the recirculation piping is controlled without the need for thermostat valves, therefore optimizing comfort.

CONSTRUCTION FEATURES

Monobloc circulation pump consisting of the cast iron hydraulic section, and the wet rotor synchronous motor. Aluminium motor casing. Scroll type pump body featuring high hydraulic efficiency thanks to highly precise design and smooth internal surfaces. In-line suction and delivery ports. The single version is supplied as standard with insulating casing, to avoid heat dispersion and/or the formation of condensation on the pump body. For the twin version, the insulation must be provided by the installer. In any case, pay attention not to obstruct the condensation drainage ducts, to avoid impairing the operation of the circulator. The EVOPLUS circulators for small collective systems are connected to the power input line using a practical connector with plug supplied as standard, which makes the operation quick and easy. Technopolymer impeller, aluminium motor shaft on graphite bushings lubricated by the pumped liquid. Stainless steel rotor protection liner. Ceramic thrust ring, ethylene-propylene seal rings and carbon fibre composite stator liner. Asynchronous motor with permanent magnet rotor. The twin version features an automatic swing check valve incorporated in the delivery port, to avoid water recirculating through the unit when this is not running; in addition, a blank flange is also supplied as standard, to allow either of the two motors to be removed for servicing. PN 16 standard pump body execution, flanged with 4 holes, compatible with PN 6 / PN 10 / PN 16 counter flanges, to ensure the interchangeability of the pumps in existing systems.

EVOPLUS SMALL / EVOPLUS SMALL SAN

WET ROTOR ELECTRONIC CIRCULATORS

EVOPLUS CONSTRUCTION CHARACTERISTICS FOR SMALL COLLECTIVE SYSTEMS (ELECTRONIC DEVICE).

EVOPLUS circulators are controlled by a latest generation NPT technology IGBT device, for better efficiency and strength. The specific features are:

- Sensorless motor control
- Sine-wave PWM modulation
- High carrier frequency, to eliminate all audio band noise
- dedicated 32 bit processor
- Optimised "space vector" algorithm

An intuitive and functional user interface guarantees ease of calibration by all users. The easy to read OLED display on the control panel, 4 simple navigation keys, an in-line cascade menu featuring the latest mobile technology trends, and a wide range of functions, mean that EVOPLUS circulators are truly revolutionary products. A reliable and sturdy construction, together with a modern and innovative design, complete the product, also in terms of aesthetic value. This range is ready for the following remote commands through expansion modules:

Base Module

- Economy mode
- Circulator start/stop
- Presence/absence of system alarms
- Pump in operation notification

Multifunction Module*

- 2 x 0-10 V analogue signals
- 1 PWM signal
- 1 ΔT analogue signal from temperature sensor
- Connection to ModBus system management devices
Optional LonBus with appropriate module
- Presence/absence of system alarms
- Pump in operation notification

* Inputs available only if the associated function is active

MATERIALS

N.	PARTS	MATERIALS
1	PUMP BODY	CAST IRON 250 UNI ISO 185 - CTF BRONZE (for the SAN version)
4	IMPELLER	TECHNOPOLYMER
7A	MOTOR SHAFT	ALUMINA
7B	ROTOR	STAINLESS STEEL LINER
8	STATOR	-
10	MOTOR CASING	DIE-CAST ALUMINIUM
127	SEAL RING	EPDM RUBBER
128	STATOR LINER	STAINLESS STEEL
130	CLOSING FLANGE	STAINLESS STEEL
131	THRUST RING SUPPORT	EPDM RUBBER
132	BUSHINGS	GRAPHITE

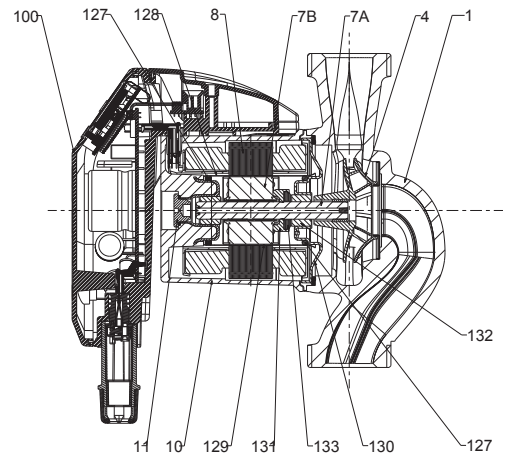

- Legend: (example)

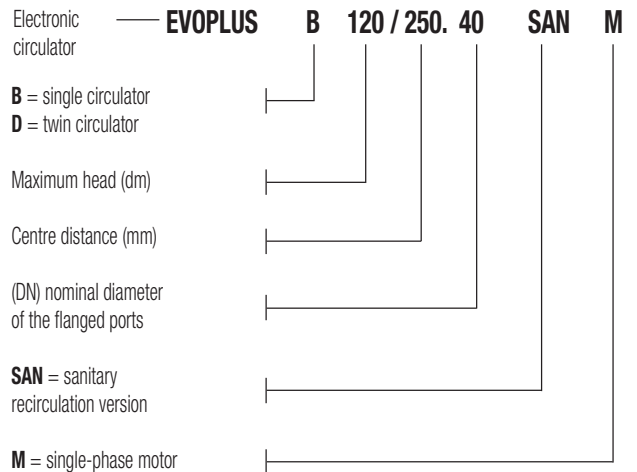
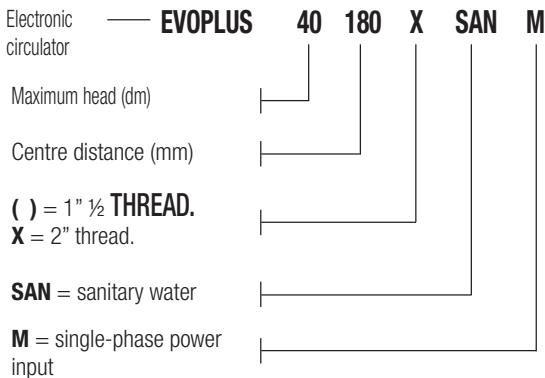

EVOPLUS SMALL / EVOPLUS SMALL SAN

WET ROTOR ELECTRONIC CIRCULATORS

MODES OF OPERATION

All the functions listed below can be consulted by the users (including less experienced ones) by simply scrolling through the menu. The calibration and the modification of the parameters are protected, and can only be completed by expert users. The factory settings of the EVOPLUS range are for proportional differential pressure control mode in the curve that ensures the best energy efficiency index (EEI).

1 - ΔP -v proportional differential pressure adjustment mode

With ΔP -v adjustment mode, with the variation of the flow rate, the value of the delivery of the head also varies in a linear manner, from H_{setp} to $H_{setp}/2$.

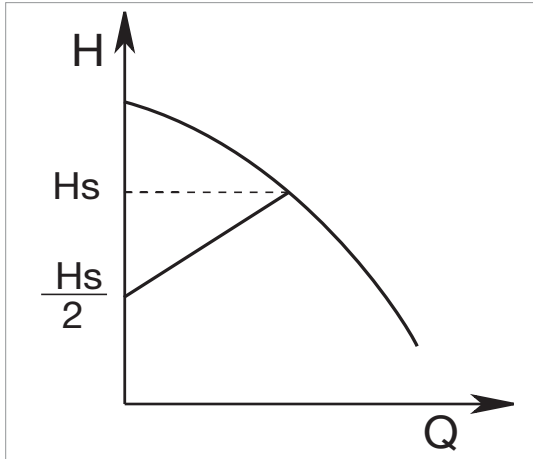

This adjustment is particularly indicated for the following systems:

a. Two-pipe heating systems with thermostat valves and with:

- head greater than 4 metres;
- very long circuit piping;
- valves with wide operating range;
- differential pressure regulators;
- high pressure drops in those parts of the system

carrying the entirety of the water flow rate;

- low differential pressure.

b. Under-floor central heating systems with thermostatic valves and significant pressure drops in the boiler circuit.

c. Systems with primary circuit pumps with high pressure drops.

Example of set-up of the set-point with ΔP -v

The following operating point is required:

$$Q = 6,5 \text{ m}^3/\text{h}$$

$$H = 6 \text{ m}$$

PROCEDURE:

1. In the graph, find the desired operating point, and then find the EVOPLUS curve closest to it (in this case the point lies precisely on the curve)
2. Follow the curve upwards until reaching the intersection with the limit curve of the circulator.
3. The head reading found at this limit point is the set-point head that must be entered to obtain the desired operating point.

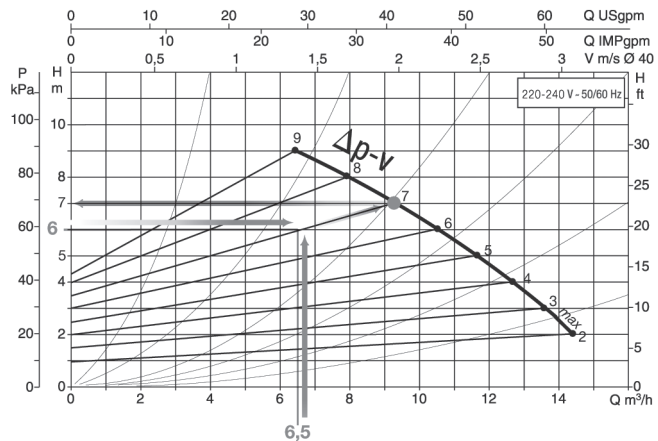

2 - ΔP -c constant differential pressure adjustment mode

The ΔP -c adjustment mode keeps the differential pressure of the system constantly at the H_{setp} value set, even in case of variation of the flow rate.

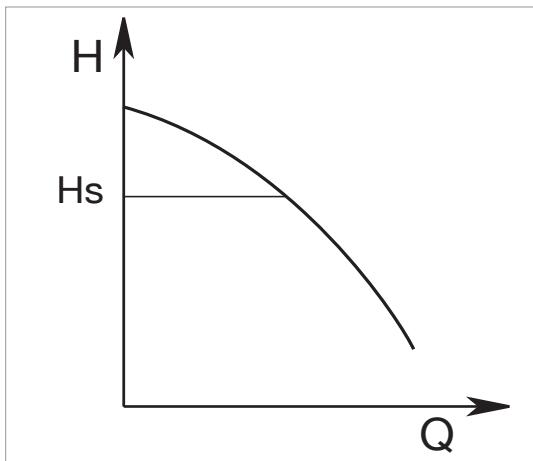

This adjustment is particularly indicated for the following systems:

a. Two-pipe heating systems with thermostat valves and with:

- head lower than 2 metres;
 - natural circulation;
 - low pressure drops in those parts of the system
- carrying the entirety of the water flow rate;
- high differential temperature (central heating).

b. underfloor heating systems with thermostat valves

c. single-pipe heating systems with thermostat valves and calibration valves

d. Systems with primary circuit pumps with low pressure drops.

EVOPLUS SMALL / EVOPLUS SMALL SAN

WET ROTOR ELECTRONIC CIRCULATORS

3 - Constant curve adjustment modes

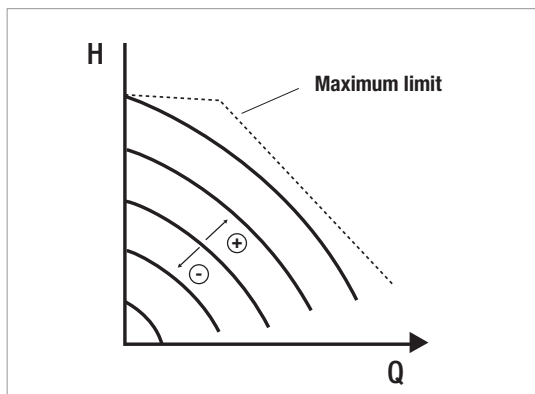

In this control mode, the circulator works based on constant speed characteristic curves. The operation curve is selected by setting the rotation speed using a percentage factor. The 100 % value indicates the maximum limit curve. The actual rotation speed may be affected by the power and differential pressure limitations of the actual circulator model. The rotation speed may be set using the display, or either a 0-10 V or PWM external signal, using the appropriate multifunction module.

Control mode indicated for constant flow rate heating and air conditioning systems.

4 - Constant differential pressure control mode with proportional control based on the water temperature (Function available with multifunction module)

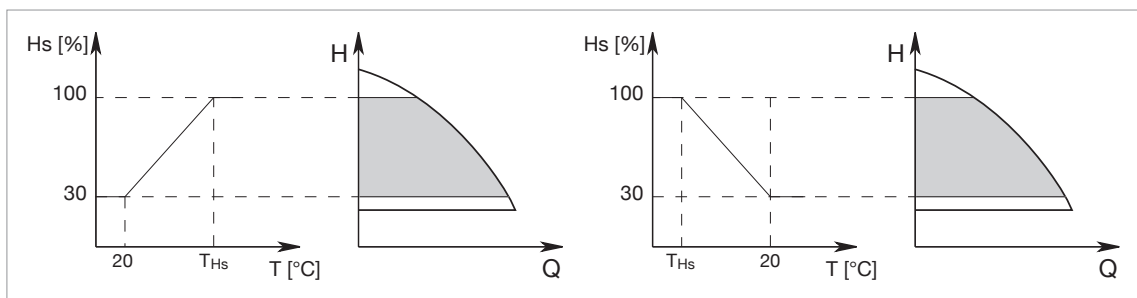

The circulator head set-point is reduced in accordance with the water temperature. The liquid temperature can be set between 0 °C to 100 °C.

This adjustment is particularly indicated for the following systems:

- a. - in variable flow rate systems (two-pipe central heating systems), in which a further reduction of circulator performance is provided in line with the lowering of the temperature of the circulating liquid, in case of reduced heating demand.
- b. - in constant flow rate systems (single-pipe and under-floor central heating systems), where the performance of the circulator can only be adjusted by activating the temperature influence function.
It is set through the EVOPLUS control panel.

5 - ΔT -c constant differential pressure control mode (Function available with multifunction mode) *

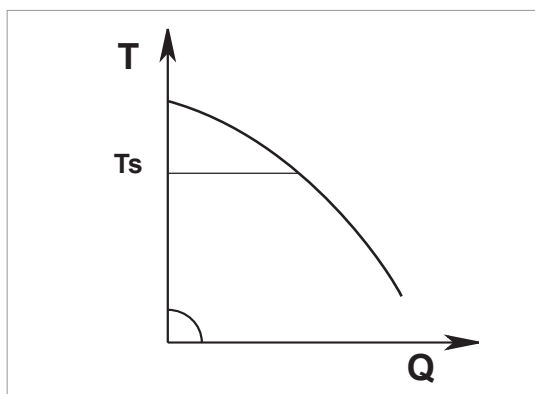

The ΔT -c control mode keeps the pumped liquid at constant temperature, changing the flow rate to the Tsetp settable value.

This adjustment is particularly indicated for the following systems:

- Under-floor heating systems.
- systems with primary circuit pumps.
- Systems with circuit pumps with heat exchanger.
- Solar energy systems with storage tanks.
- Solar panel swimming pool heating systems.

* Adjustment during implementation.

ECONOMY MODE

The economy function can be set directly on the control panel, by setting a reduction value (f.rid), the maximum value of which can be 50%. In all the previously listed settings, the Hset value must be replaced with an Hset x f.rid.

EVOPLUS SMALL / EVOPLUS SMALL SAN

WET ROTOR ELECTRONIC CIRCULATORS

BASE MODULE

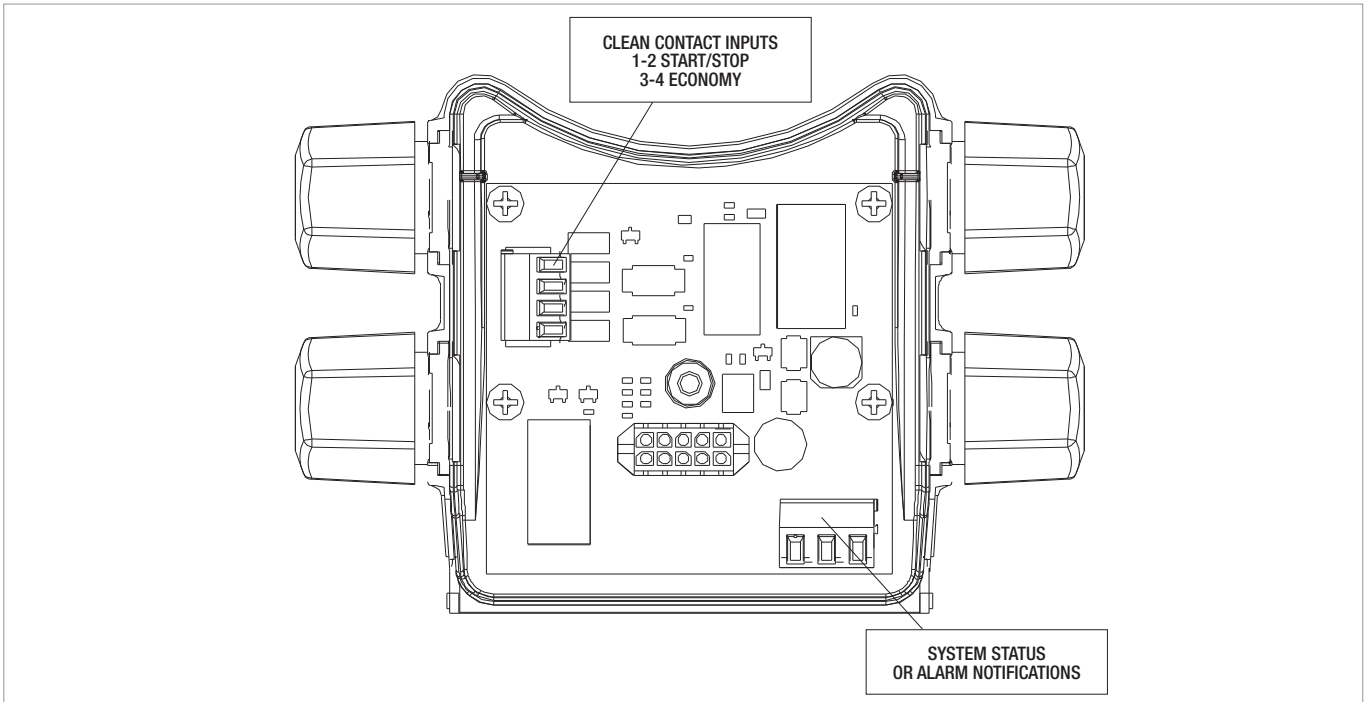

Digital inputs

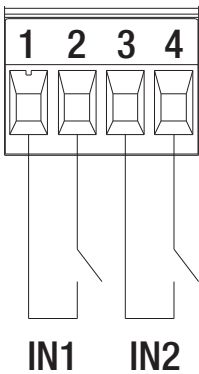

Clean contact inputs
1-2 START/STOP
3-4 ECONOMY

Input	Terminal no.	Type of contact	Associated function
IN1	1	Clean contact	EXT: If it is activated from the control panel, it will be possible to remotely control the switching on and off of the pump.
	2		
IN2	3	Clean contact	Economy: If it is activated from the control panel, it will be possible to remotely activate the set-point reduction function.
	4		

If the **EXT** and **Economy** functions have been activated using the control panel, the system will behave as follows:

IN1	IN2	System status
Open	Open	Pump stopped
Open	Close	Pump stopped
Close	Open	Pump in operation with set-point set by the user
Close	Close	Pump in operation with reduced set-point

Digital outputs

System status or alarm notifications

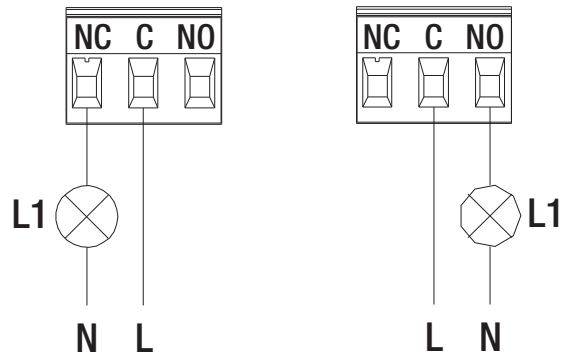

The function associated to OUT1 is "Alarms Present"; L1 turns on when a system alarm is present, and turns off when no fault is detected.

The function associated with OUT1 is "Pump Status"; L1 turns on when the pump is in operation, and stops when the pump is idle.

Output	Terminal no.	Type of contact	Associated function
OUT1	NC	NC	<ul style="list-style-type: none"> • Presence/absence of system alarms • Pump in operation/Pump stopped
	C	COM	
	NO	NO	

The OUT1 output is available on the 3-pole removable terminal box, where the type of contact is also shown (NC = Normally Closed, COM = Common, NO = Normally Open).

Characteristics of the output contacts	
Max sustainable voltage [V]	250
Max sustainable current [A]	5 - If resistive load 2,5 - If inductive load
Max cable section accepted [mm ²]	1,5

EVOPLUS SMALL / EVOPLUS SMALL SAN

WET ROTOR ELECTRONIC CIRCULATORS

MULTIFUNCTION MODULE

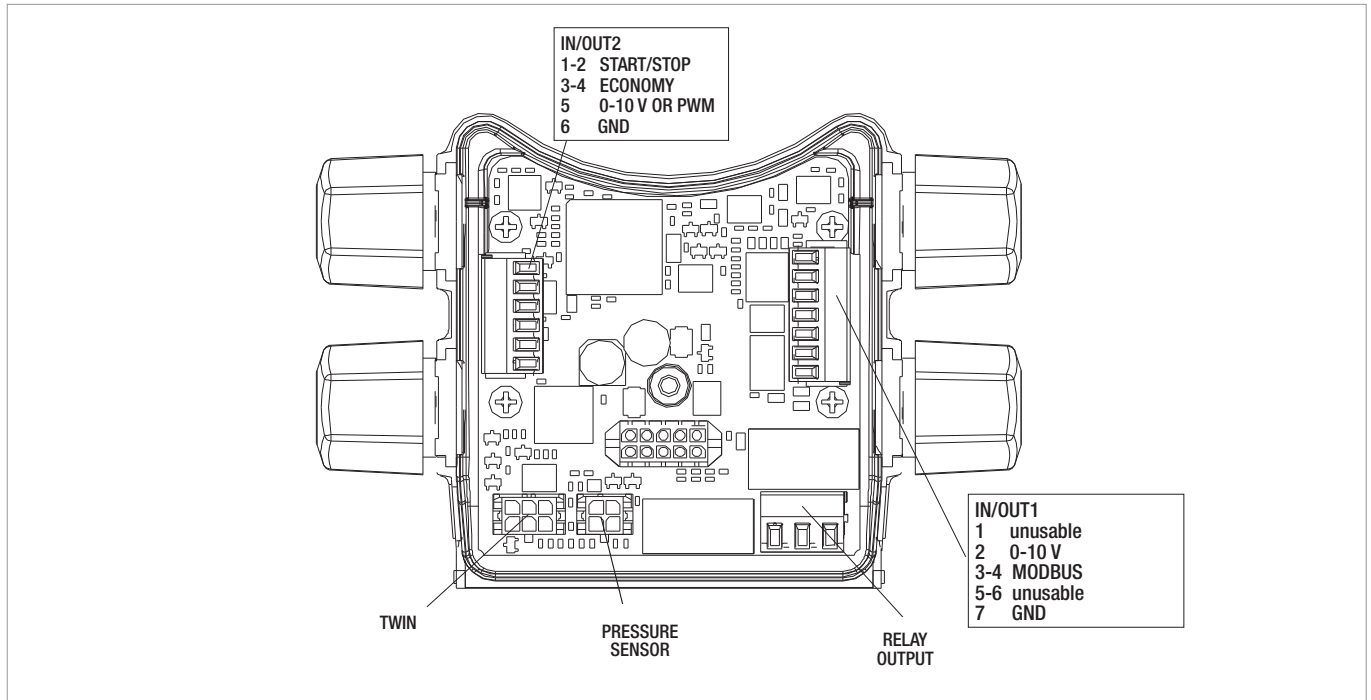

Digital inputs

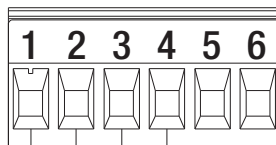

IN1 IN2

IN/OUT2
 1-2 START/STOP
 3-4 ECONOMY
 5 0-10V, PWM and NTC
 6 GND

Input	Terminal no.	Type of contact	Associated function
IN1	1	Clean contact	EXT: If it is activated from the control panel, it will be possible to remotely control the switching on and off of the pump.
	2		
IN2	3	Clean contact	Economy: If it is activated from the control panel, it will be possible to remotely activate the set-point reduction function.
	4		

If the **EXT** and **Economy** functions have been activated using the control panel, the system will behave as follows:

IN1	IN2	System status
Open	Open	Pump stopped
Open	Close	Pump stopped
Close	Open	Pump in operation with set-point set by the user
Close	Close	Pump in operation with reduced set-point

MODBUS

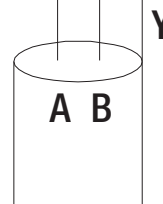
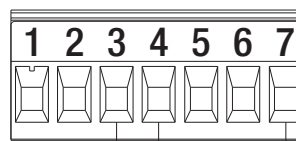

IN/OUT1
 1 unusable
 2 0-10 V
 3-4 modbus
 5-6 unusable
 7 GND

The multifunction expansion module provides serial communication through an RS-485 input. The communication is established in accordance with the MODBUS specifications.

Using the MODBUS, it is possible to remotely set the circulator operating parameters, like the desired differential pressure, the control mode, etc. At the same time, the circulator can provide important information on the status of the system.

Modbus terminals	Terminal no.	Description
A	3	Terminal not inverted (+)
B	4	Terminal inverted (+)
Y	7	GND

LONBUS

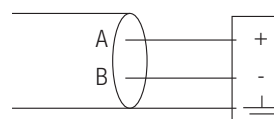

Gateway/ Evoplus connection

Using some modules available on the market, the circulator, and therefore its status, can also be made available to a LonWorks network. It will then be possible to change the parameters of the circulator by reading and amending the registers as indicated in the "Modbus Protocol instruction manual", available at the following address: "<http://www.dabpumps.it/evoplus>".

EVOPLUS SMALL / EVOPLUS SMALL SAN

WET ROTOR ELECTRONIC CIRCULATORS

PWM AND NTC ANALOGUE INPUT

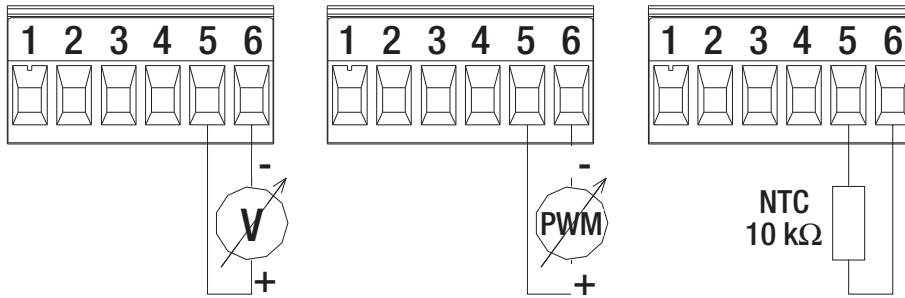

DIGITAL OUTPUTS

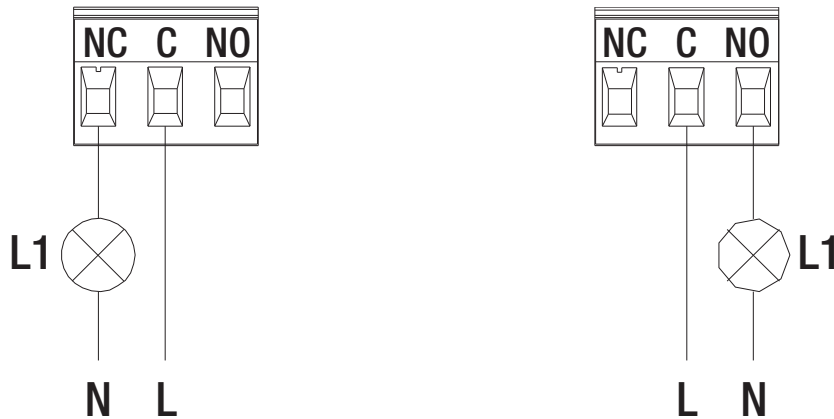

The function associated with OUT1 is "Pump Status"; L1 turns on when the pump is in operation, and stops when the pump is idle.

The function associated to OUT1 is "Alarms Present"; L1 turns on when a system alarm is present, and turns off when no fault is detected.

Output	Terminal no.	Type of contact	Associated function
OUT1	NC	NC	<ul style="list-style-type: none"> • Presence/absence of system alarms • Pump in operation/Pump stopped
	C	COM	
	NO	NO	

The OUT1 output is available on the 3-pole removable terminal box, where the type of contact is also shown (NC = Normally Closed, COM = Common, NO = Normally Open).

Characteristics of the output contacts	
Max sustainable voltage [V]	250
Max sustainable current [A]	5 - If resistive load 2,5 - If inductive load
Max cable section accepted [mm ²]	1,5

EVOPLUS RANGE

WET ROTOR ELECTRONIC CIRCULATORS

PERFORMANCE RANGE

The performance curves are based on kinematic viscosity values = 1 mm²/s and density equal to 1000 kg/m³. Curve tolerance according to ISO 9906.

GRAPHIC SELECTION TABLE

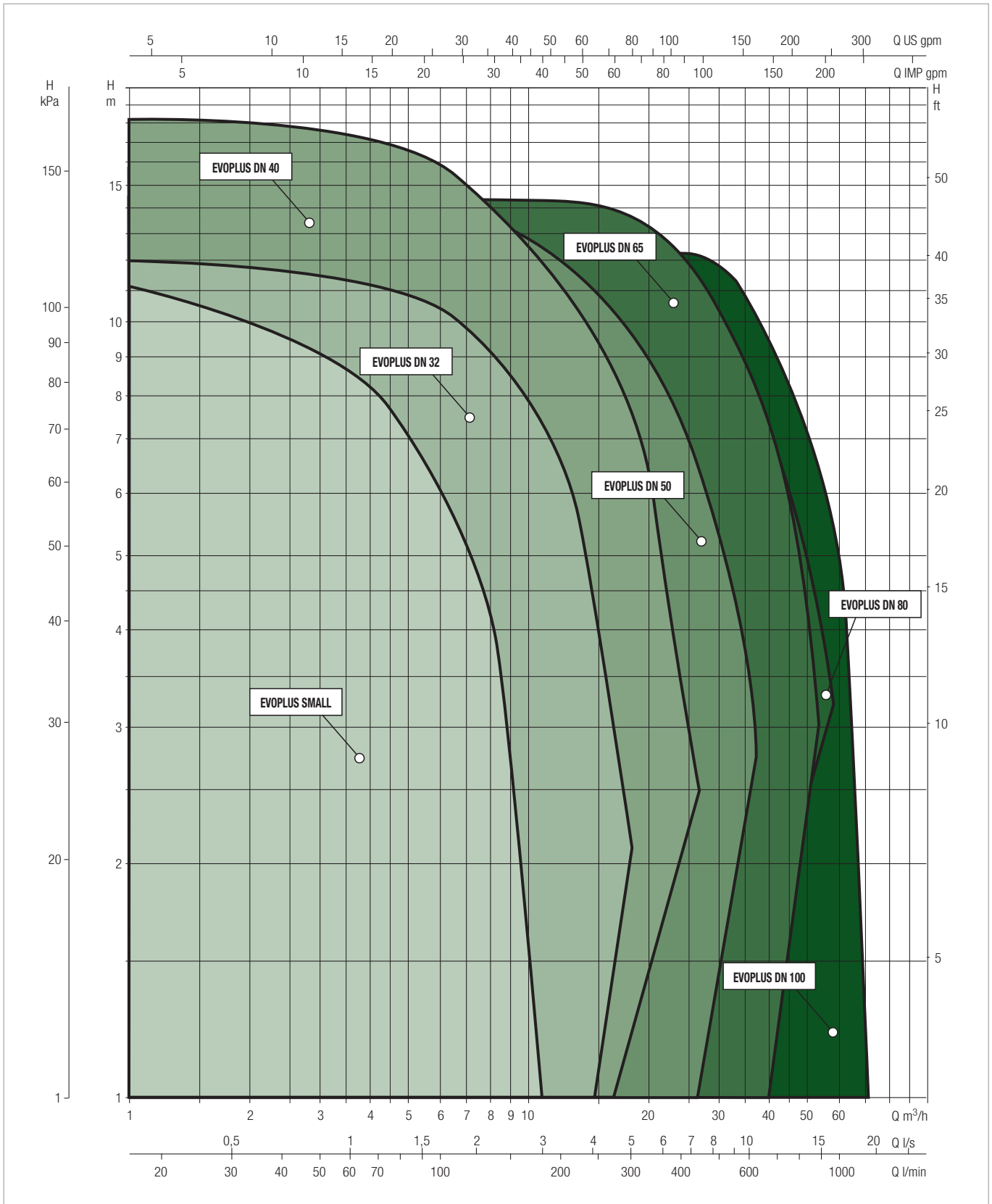

EVOPLUS SMALL / EVOPLUS SMALL SAN

WET ROTOR ELECTRONIC CIRCULATORS

SELECTION TABLE - EVOPLUS SMALL

MODEL	Q=m ³ /h	0	2,4	3	4,2	5,4	7,2	9,6
	Q=l/min	0	40	50	70	90	120	160
EVOPLUS 40/180 M	H (m)	4,2	4,2	4	3,1	2,4		
EVOPLUS 60/180 M		6,1	6,1	5,8	4,6	3,4		
EVOPLUS 80/180 M		8,2	8,2	7,7	6,2	4,8	2,9	
EVOPLUS 110/180 M		11,1	10,1	9,2	7,5	5,9	3,9	
EVOPLUS 40/180 XM		4,1	4,1	4	3,1	2,2		
EVOPLUS 60/180 XM		6,1	6,1	5,7	4,5	3,4		
EVOPLUS 80/180 XM		8,1	8,1	7,6	6,2	4,9	3	
EVOPLUS 110/180 XM		11,3	10,2	9,5	7,9	6,3	4,3	2
EVOPLUS B 40/220.32 M		4,2	4,2	4,2	3,3	2,5	1,3	
EVOPLUS B 60/220.32 M		6,1	6,1	5,6	4,6	3,6	2,2	
EVOPLUS B 80/220.32 M		8	8	7,3	6	4,9	3,3	
EVOPLUS B 110/220.32 M		11,2	10,5	9,6	8,1	6,8	5	2,6
EVOPLUS B 40/250.40 M		4,2	4,2	4,2	3,3	2,5	1,3	
EVOPLUS B 60/250.40 M		6,1	6,1	5,6	4,6	3,6	2,2	
EVOPLUS B 80/250.40 M		8	8	7,3	6	4,9	3,3	
EVOPLUS B 110/250.40 M		11,2	10,5	9,6	8,1	6,8	5	2,6
EVOPLUS D 40/220.32 M		4,2	4,2	4,2	3,3	2,5	1,3	
EVOPLUS D 60/220.32 M		6,1	6,1	5,6	4,6	3,6	2,2	
EVOPLUS D 80/220.32 M		8	8	7,3	6	4,9	3,3	
EVOPLUS D 110/220.32 M		11,2	10,5	9,6	8,1	6,8	5	2,6
EVOPLUS D 40/250.40 M		4,2	4,2	4,2	3,3	2,5	1,3	
EVOPLUS D 60/250.40 M		6,1	6,1	5,6	4,6	3,6	2,2	
EVOPLUS D 80/250.40 M		8	8	7,3	6	4,9	3,3	
EVOPLUS D 110/250.40 M		11,2	10,5	9,6	8,1	6,8	5	2,6

SELECTION TABLE - EVOPLUS SMALL SAN

MODEL	Q=m ³ /h	0	2,4	3	4,2	5,4	7,2	9,6
	Q=l/min	0	40	50	70	90	120	160
EVOPLUS 40/180 SAN M	H (m)	4,2	4,2	4	3,1	2,4		
EVOPLUS 60/180 SAN M		6,1	6,1	5,8	4,6	3,4		
EVOPLUS 80/180 SAN M		8,2	8,2	7,7	6,2	4,8	2,9	
EVOPLUS 110/180 SAN M		11,1	10,1	9,2	7,5	5,9	3,9	
EVOPLUS B 40/220.32 SAN M		4,2	4,2	4,2	3,3	2,5	1,3	
EVOPLUS B 60/220.32 SAN M		6,1	6,1	5,6	4,6	3,6	2,2	
EVOPLUS B 80/220.32 SAN M		8	8	7,3	6	4,9	3,3	
EVOPLUS B 110/220.32 SAN M		11,2	10,5	9,6	8,1	6,8	5	2,6
EVOPLUS B 40/250.40 SAN M		4,2	4,2	4,2	3,3	2,5	1,3	
EVOPLUS B 60/250.40 SAN M		6,1	6,1	5,6	4,6	3,6	2,2	
EVOPLUS B 80/250.40 SAN M		8	8	7,3	6	4,9	3,3	
EVOPLUS B 110/250.40 SAN M		11,2	10,5	9,6	8,1	6,8	5	2,6

EVOPLUS SMALL - ELECTRONIC CIRCULATORS FOR HEATING AND AIR CONDITIONING SYSTEMS - SINGLE, WITH UNIONS

Pumped liquid temperature range: from -10 °C to +110 °C - Maximum operating pressure: 16 bar (1600 kPa)

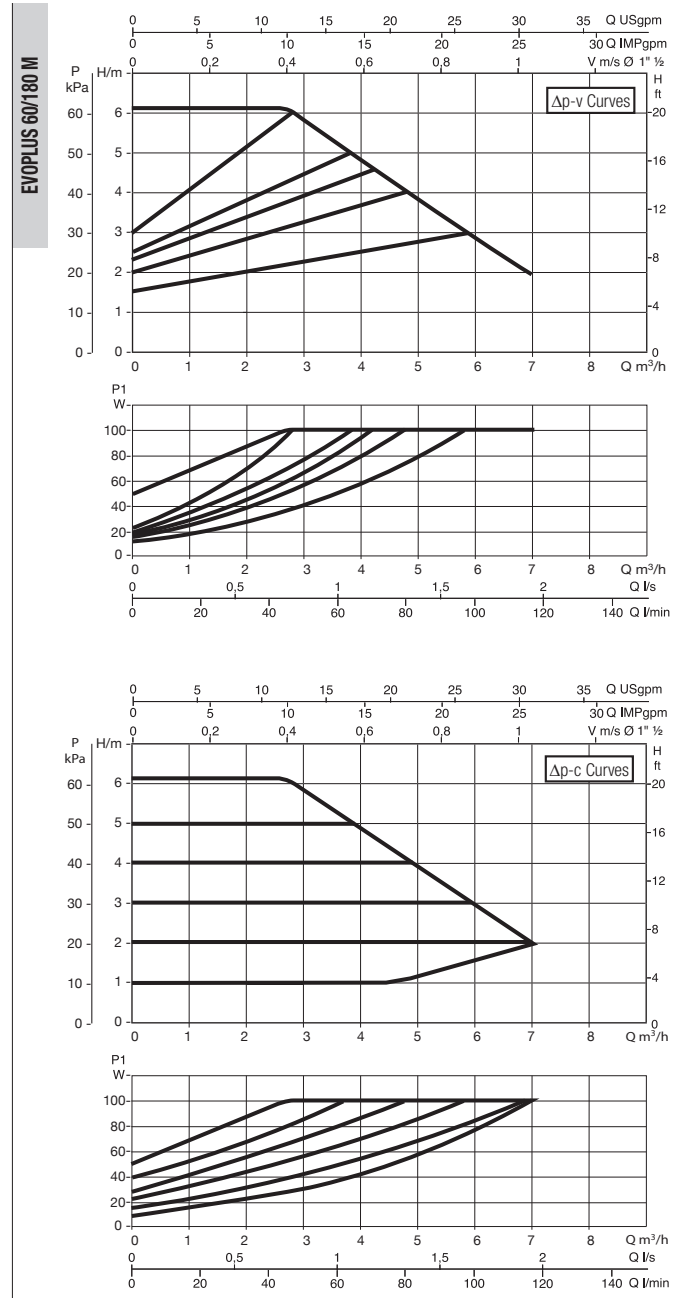
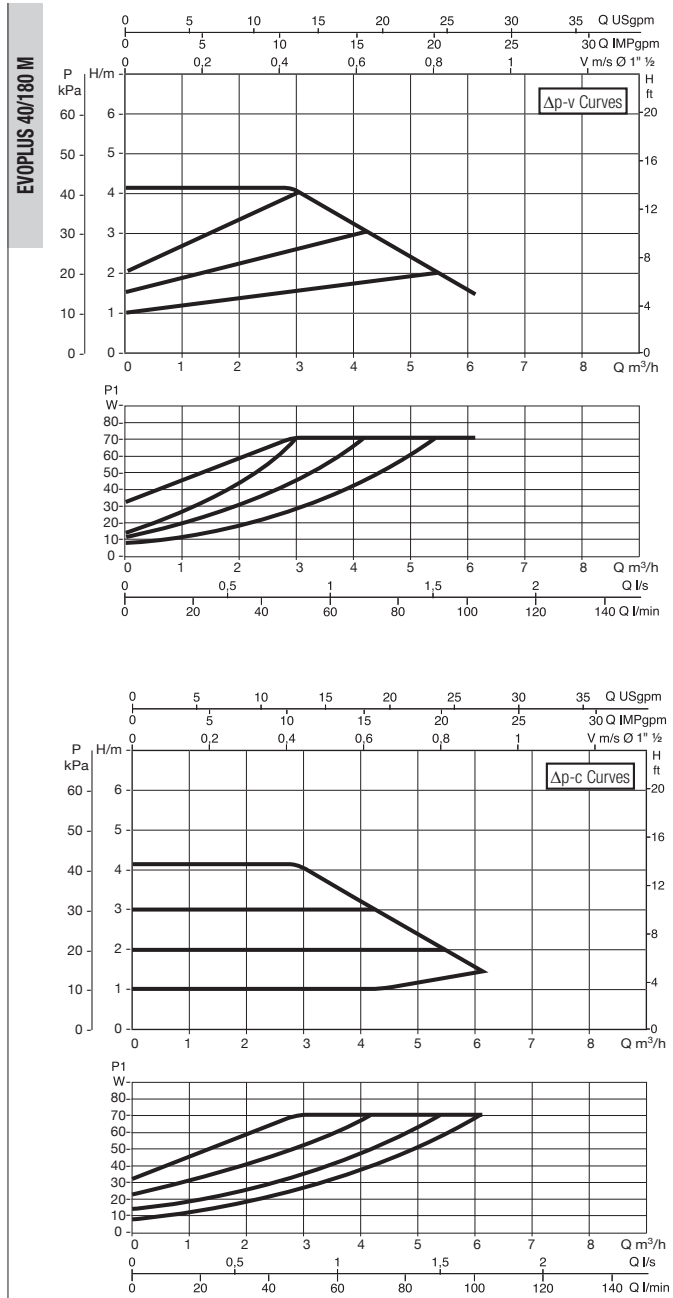

The curves are based on kinematic viscosity values = 1 mm²/s and density equal to 1000 kg/m³. Curve tolerance according to ISO 9906. Fixed speed curves available on the DNA.

MODEL	CENTRE DISTANCE mm	UNIONS ON REQUEST		POWER INPUT 50/60 Hz	P1 MAX W	In A	EEI *	MINIMUM SUCTION PRESSURE			WEIGHT kg
		STANDARDISED	SPECIAL					t°	90 °	100°	
EVOPLUS 40/180 M	180	1" F	¾" F - 1¼" M	220/240 V	70	0,52	EEI ≤ 0,23	m.c.w.	20	25	4,5
EVOPLUS 60/180 M	180	1" F	¾" F - 1¼" M	220/240 V	100	0,72	EEI ≤ 0,22	m.c.w.	20	25	4,5

The parameter of reference for the more efficient circulators is EEI ≥ 0,20.

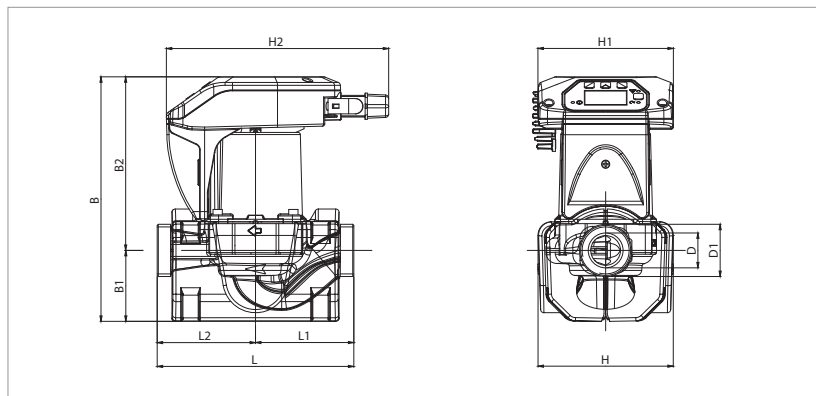

L	L1	L2	B	B1	B2
180	90	90	224	65	159

D	D1	H	H1	H2
32	1½	124	124	204

EVOPLUS SMALL - ELECTRONIC CIRCULATORS FOR HEATING AND AIR CONDITIONING SYSTEMS - SINGLE, WITH UNIONS

Pumped liquid temperature range: from -10 °C to +110 °C - Maximum operating pressure: 16 bar (1600 kPa)

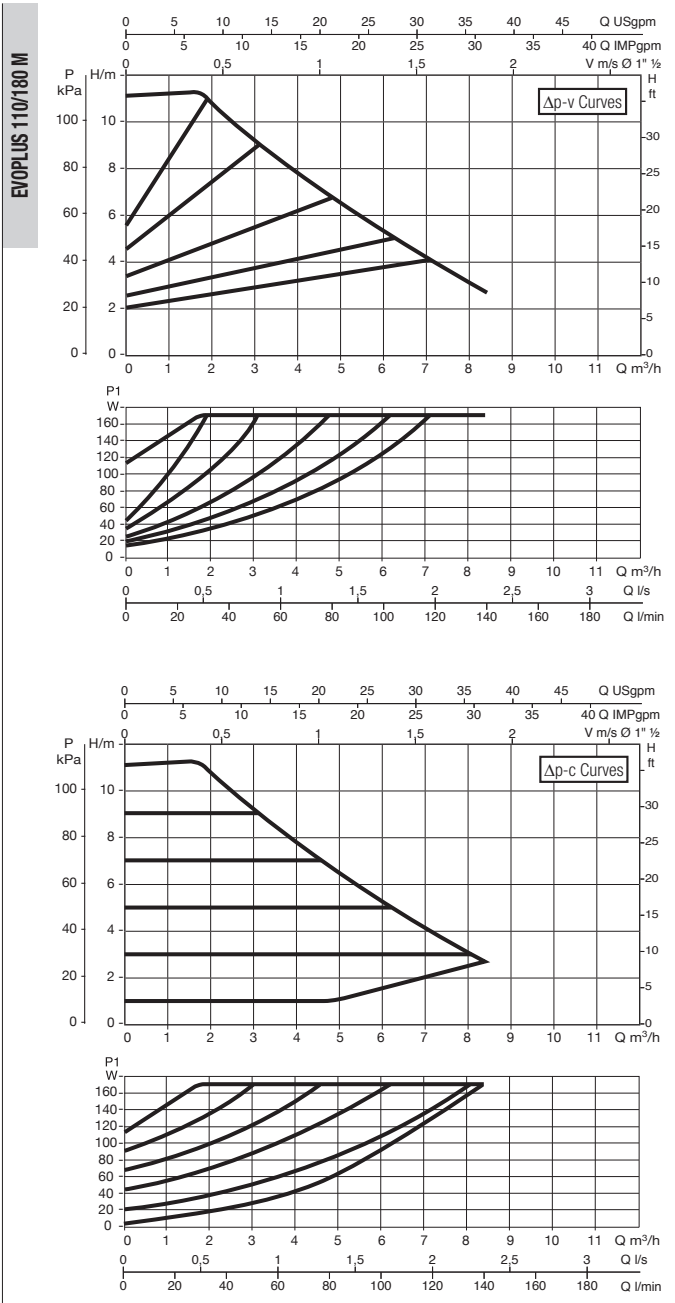
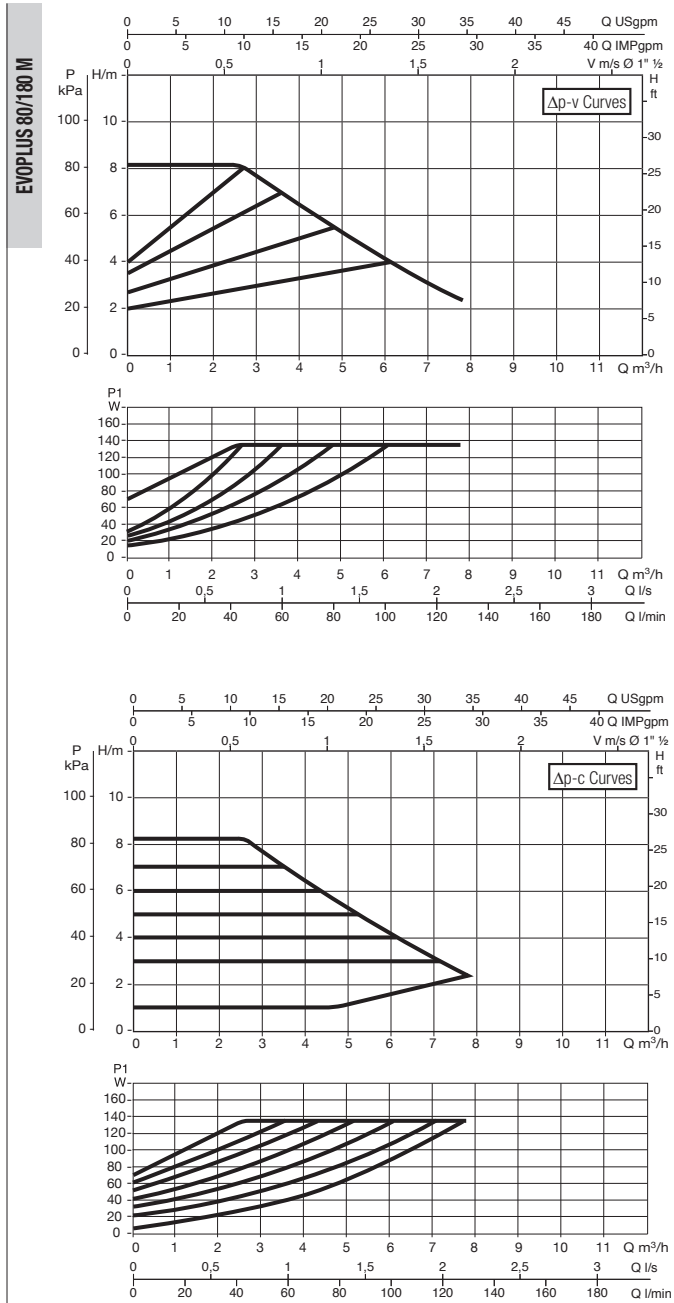

The curves are based on kinematic viscosity values = 1 mm²/s and density equal to 1000 kg/m³. Curve tolerance according to ISO 9906. Fixed speed curves available on the DNA.

MODEL	CENTRE DISTANCE mm	UNIONS ON REQUEST		POWER INPUT 50/60 Hz	P1 MAX W	In A	EEI *	MINIMUM SUCTION PRESSURE			WEIGHT kg
		STANDARDISED	SPECIAL					t°	90 °	100°	
EVOPLUS 80/180 M	180	1" F	¾" F - 1¼" M	220/240 V	135	0,95	EEI ≤ 0,22	m.c.w.	20	25	4,5
EVOPLUS 110/180 M	180	1" F	¾" F - 1¼" M	220/240 V	170	1,18	EEI ≤ 0,22	m.c.w.	20	25	4,5

The parameter of reference for the more efficient circulators is EEI ≥ 0,20.

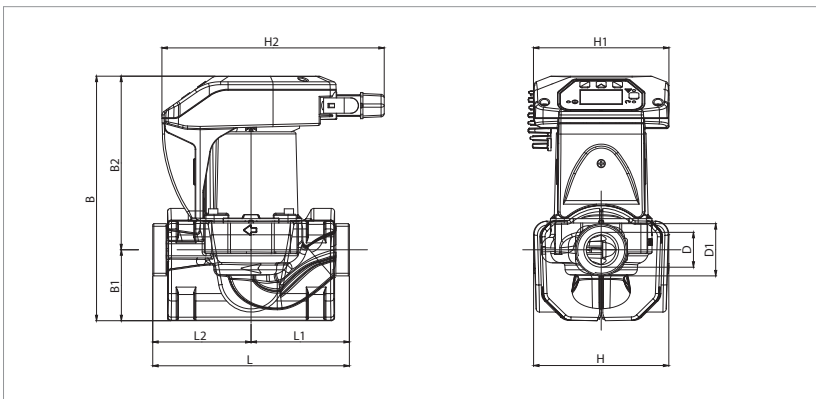

L	L1	L2	B	B1	B2
180	90	90	224	65	159

D	D1	H	H1	H2
32	1½	124	124	204

EVOPLUS SMALL - ELECTRONIC CIRCULATORS FOR HEATING AND AIR CONDITIONING SYSTEMS - SINGLE, WITH UNIONS

Pumped liquid temperature range: from -10 °C to +110 °C - Maximum operating pressure: 16 bar (1600 kPa)

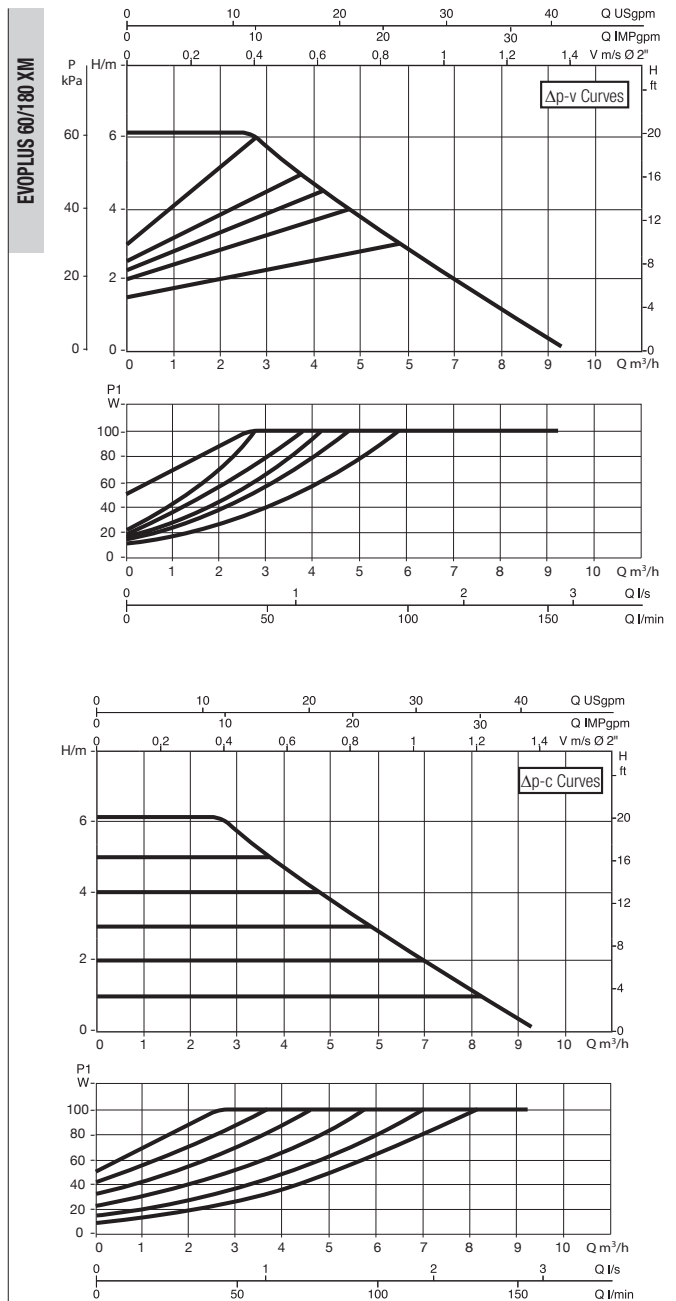
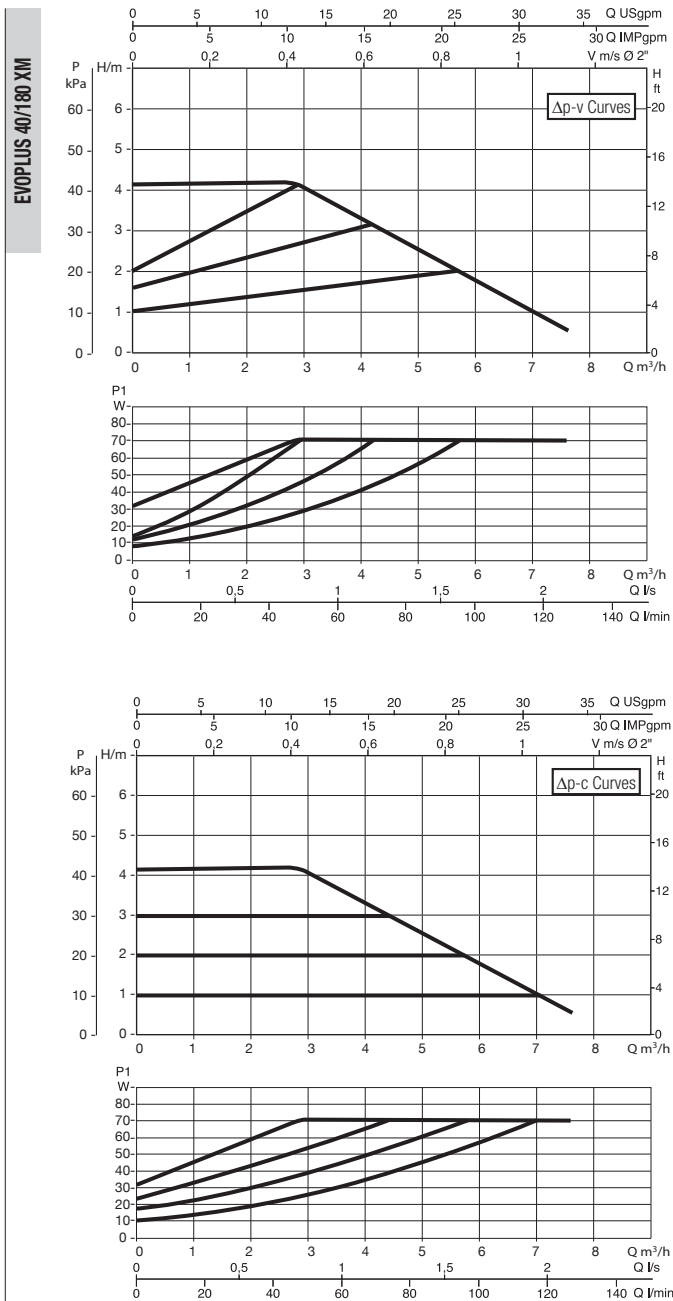

The curves are based on kinematic viscosity values = 1 mm²/s and density equal to 1000 kg/m³. Curve tolerance according to ISO 9906. Fixed speed curves available on the DNA.

MODEL	CENTRE DISTANCE mm	UNIONS ON REQUEST		POWER INPUT 50/60 Hz	P1 MAX W	In A	EEI *	MINIMUM SUCTION PRESSURE			WEIGHT kg
		STANDARDISED	SPECIAL					t°	90 °	100°	
EVOPLUS 40/180 XM	180	2" G	1 1/4" F	220/240 V	70	0,51	EEI ≤ 0,21	m.c.w.	20	25	4,7
EVOPLUS 60/180 XM	180	2" G	1 1/4" F	220/240 V	100	0,71	EEI ≤ 0,21	m.c.w.	20	25	4,7

The parameter of reference for the more efficient circulators is EEI ≥ 0,20.

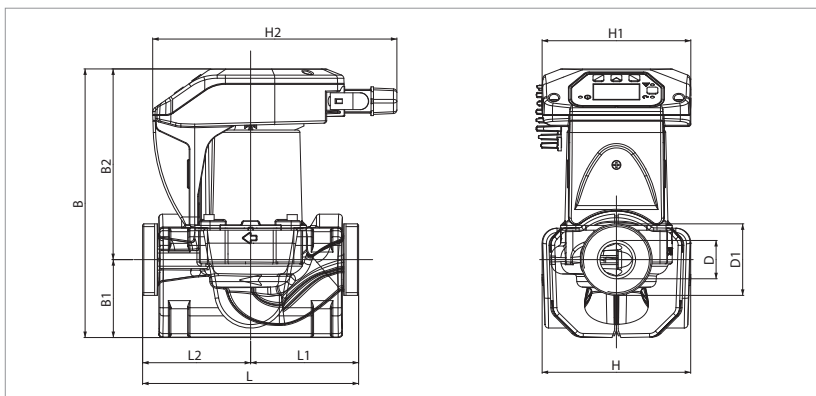

L	L1	L2	B	B1	B2
180	90	90	224	65	159

D	D1	H	H1	H2
32	2"	124	124	204

EVOPLUS SMALL - ELECTRONIC CIRCULATORS FOR HEATING AND AIR CONDITIONING SYSTEMS - SINGLE, WITH UNIONS

Pumped liquid temperature range: from -10 °C to +110 °C - Maximum operating pressure: 16 bar (1600 kPa)

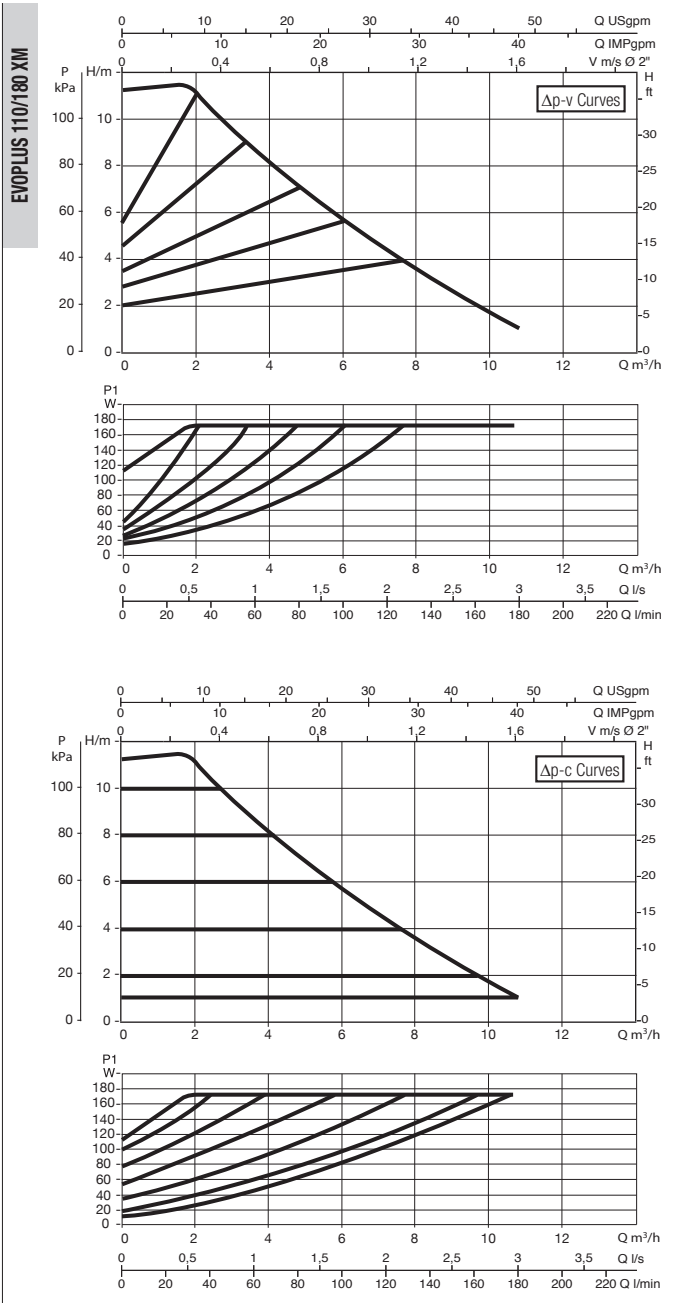
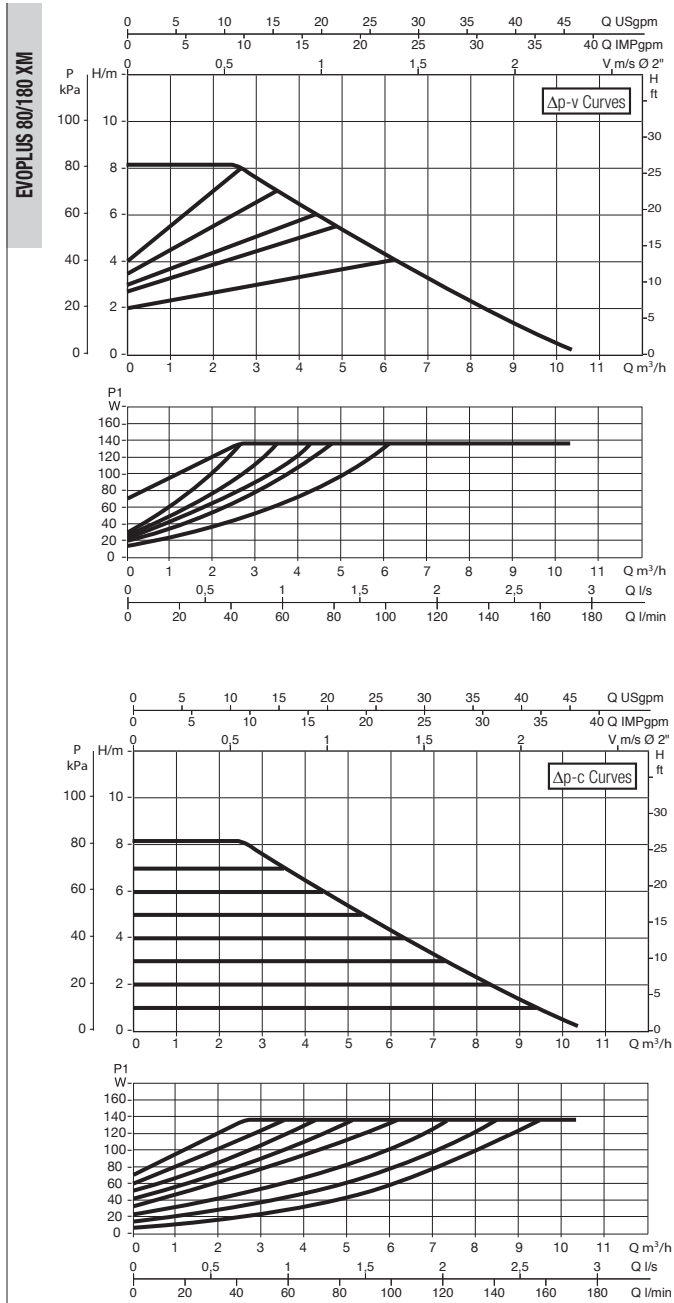

The curves are based on kinematic viscosity values = 1 mm²/s and density equal to 1000 kg/m³. Curve tolerance according to ISO 9906. Fixed speed curves available on the DNA.

MODEL	CENTRE DISTANCE mm	UNIONS ON REQUEST		POWER INPUT 50/60 Hz	P1 MAX W	In A	EEI *	MINIMUM SUCTION PRESSURE			WEIGHT kg
		STANDARDISED	SPECIAL					t°	90 °	100°	
EVOPLUS 80/180 XM	180	2" G	1¼" F	220/240 V	135	0,93	EEI ≤ 0,21	m.c.w.	20	25	4,7
EVOPLUS 110/180 XM	180	2" G	1¼" F	220/240 V	170	1,18	EEI ≤ 0,21	m.c.w.	20	25	4,7

The parameter of reference for the more efficient circulators is EEI ≥ 0,20.

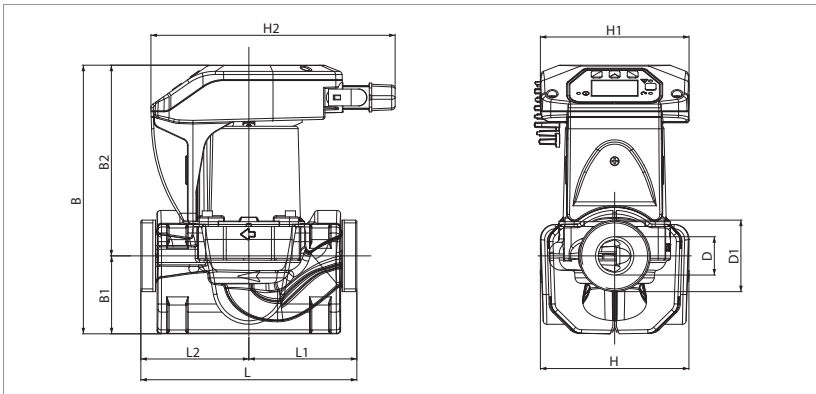

L	L1	L2	B	B1	B2
180	90	90	224	65	159

D	D1	H	H1	H2
32	2"	124	124	204



EVOPLUS SMALL - ELECTRONIC CIRCULATORS FOR HEATING AND AIR CONDITIONING SYSTEMS - SINGLE, FLANGED

Pumped liquid temperature range: from -10 °C to +110 °C - Maximum operating pressure: 16 bar (1600 kPa)

EVOPLUS B 40/220.32 M

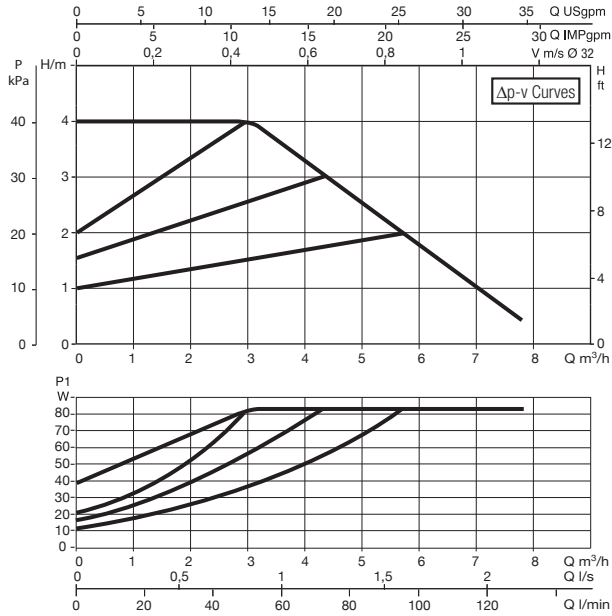

EVOPLUS B 60/220.32 M

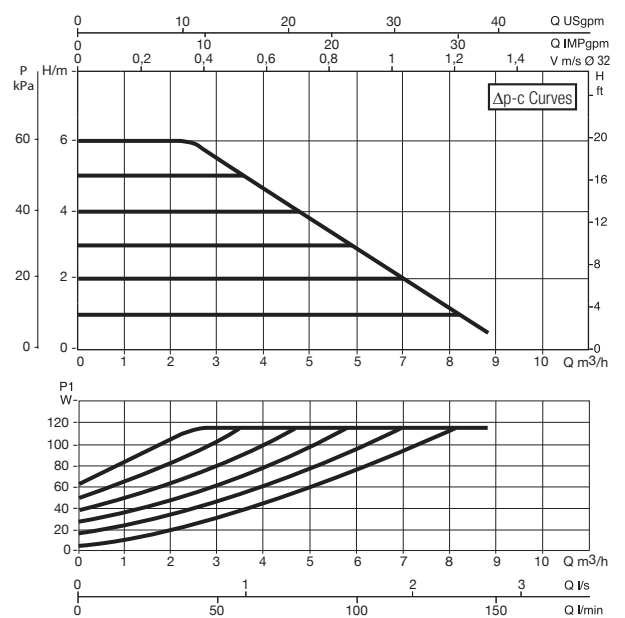
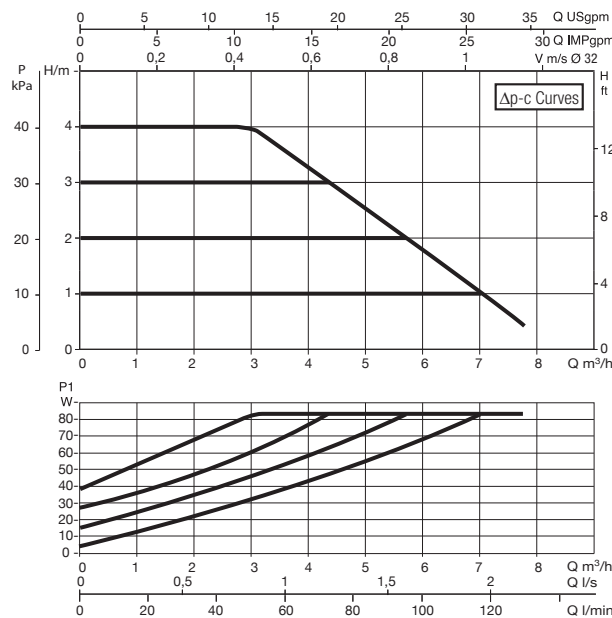
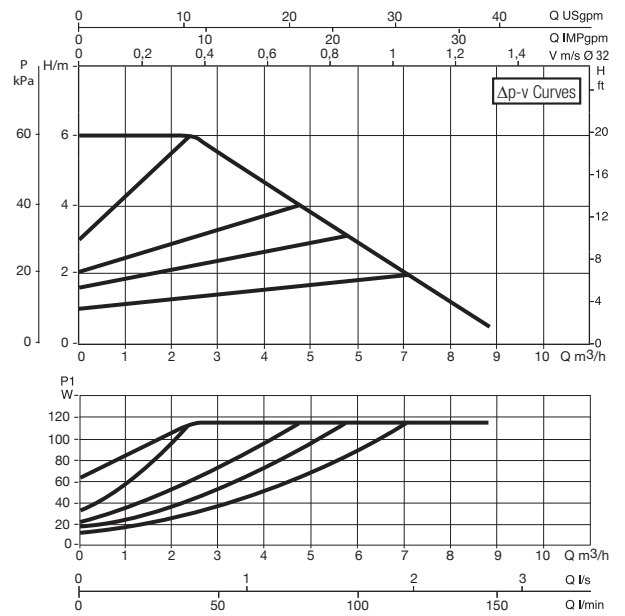

The curves are based on kinematic viscosity values = 1 mm²/s and density equal to 1000 kg/m³. Curve tolerance according to ISO 9906. Fixed speed curves available on the DNA.

MODEL	CENTRE DISTANCE mm	COUNTER FLANGES ON REQUEST	POWER INPUT 50/60 Hz	P1 MAX W	In A	EEI *	MINIMUM SUCTION PRESSURE			WEIGHT kg
							t°	90°	100°	
EVOPLUS B 40/220.32 M	220	DN 32 PN 6	220/240 V	85	0,55	EEI ≤ 0,22	m.c.w.	20	25	7,5
EVOPLUS B 60/220.32 M	220	DN 32 PN 6	220/240 V	110	0,75	EEI ≤ 0,22	m.c.w.	20	25	7,5

The parameter of reference for the more efficient circulators is EEI ≥ 0,20.

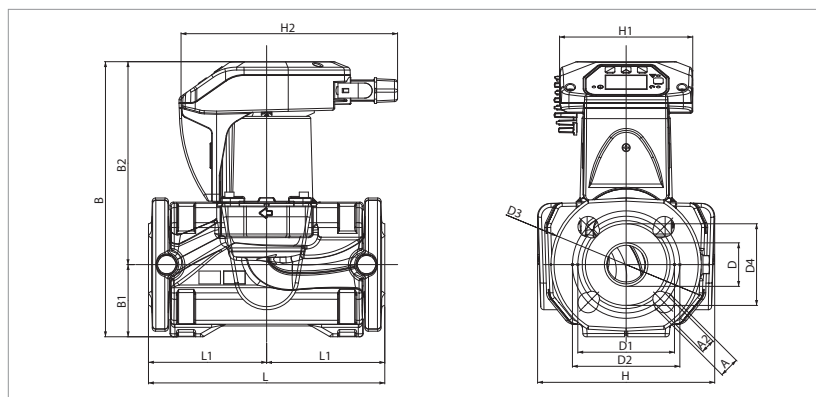

L	L1	L2	A	A2	B	B1	B2
220	110	110	19	14	256	67	189

D	D1	D2	D3	D4	H	H1	H2
40	90	100	140	76	165	124	204

EVOPLUS SMALL - ELECTRONIC CIRCULATORS FOR HEATING AND AIR CONDITIONING SYSTEMS - SINGLE, FLANGED

Pumped liquid temperature range: from -10 °C to +110 °C - Maximum operating pressure: 16 bar (1600 kPa)

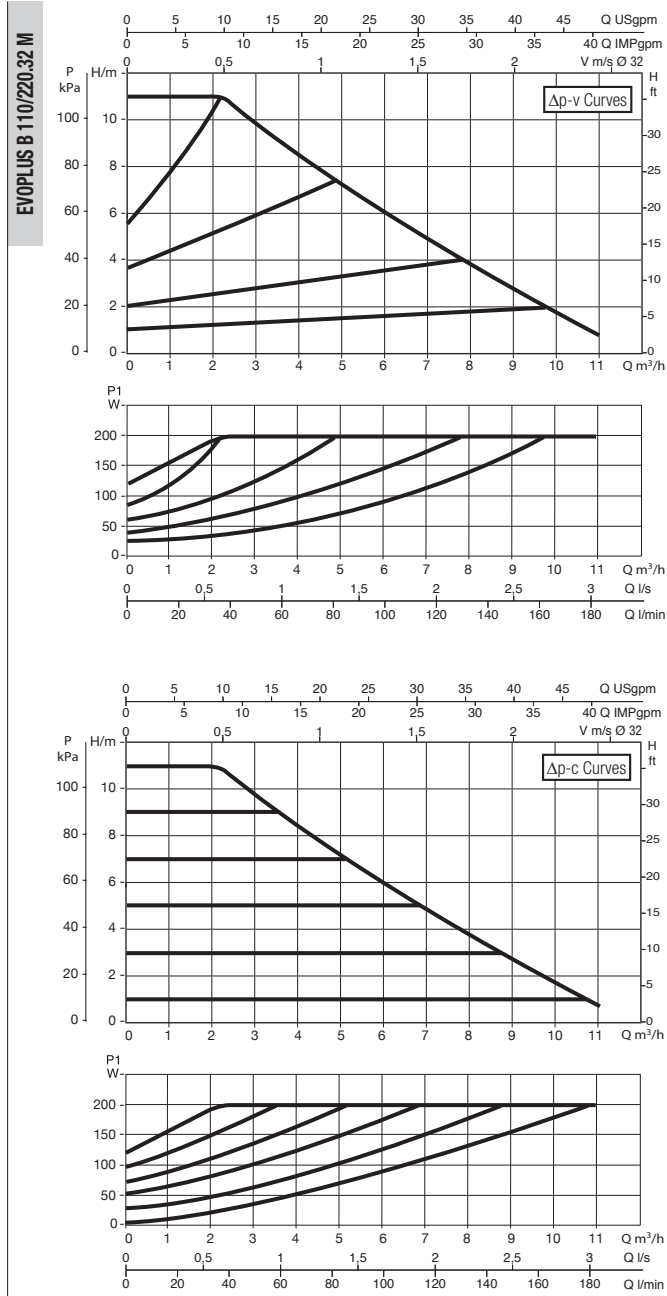
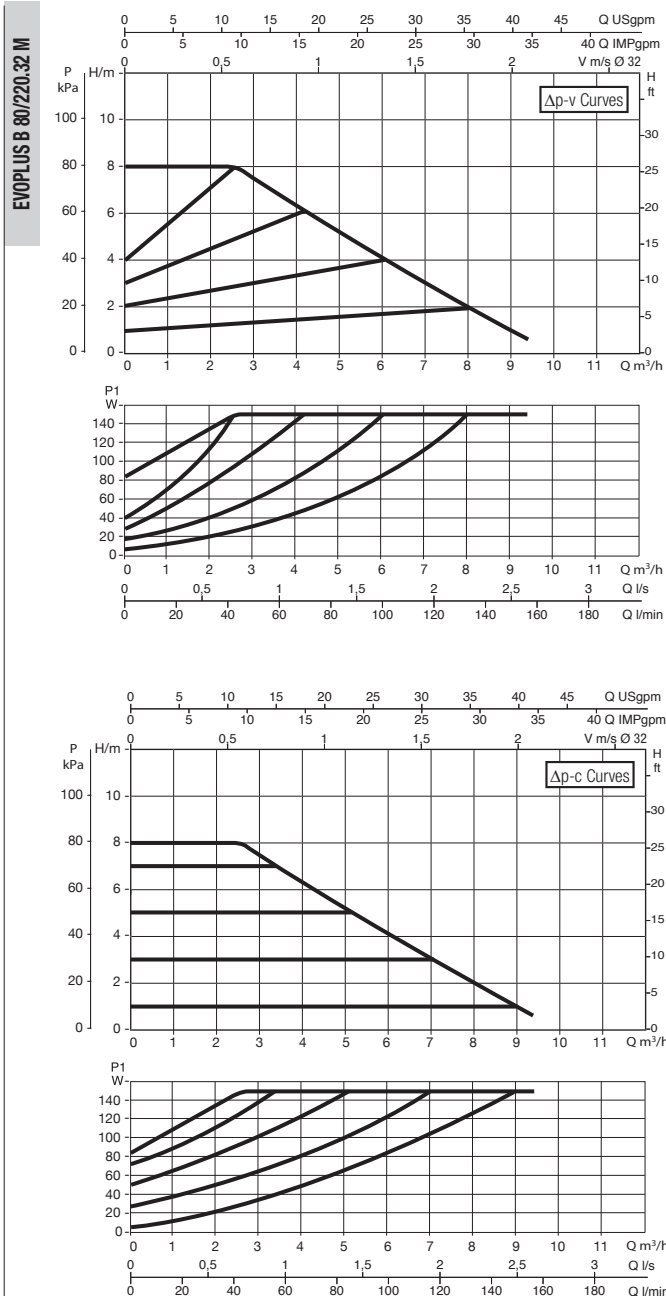

The curves are based on kinematic viscosity values = 1 mm²/s and density equal to 1000 kg/m³. Curve tolerance according to ISO 9906. Fixed speed curves available on the DNA.

MODEL	CENTRE DISTANCE mm	COUNTER FLANGES ON REQUEST	POWER INPUT 50/60 Hz	P1 MAX W	In A	EEI *	MINIMUM SUCTION PRESSURE			WEIGHT kg
							t°	90 °	100°	
EVOPLUS B 80/220.32 M	220	DN 32 PN 6	220/240 V	150	0,97	EEI ≤ 0,22	m.c.w.	20	25	7,5
EVOPLUS B 110/220.32 M	220	DN 32 PN 6	220/240 V	200	1,3	EEI ≤ 0,22	m.c.w.	20	25	7,5

The parameter of reference for the more efficient circulators is EEI ≥ 0,20.

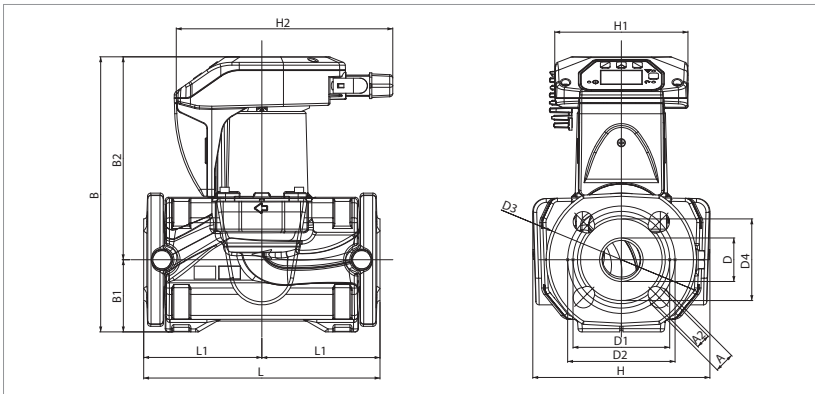

L	L1	L2	A	A2	B	B1	B2
220	110	110	19	14	256	67	189

D	D1	D2	D3	D4	H	H1	H2
40	90	100	140	76	165	124	204

EVOPLUS SMALL - ELECTRONIC CIRCULATORS FOR HEATING AND AIR CONDITIONING SYSTEMS - SINGLE, FLANGED

Pumped liquid temperature range: from -10 °C to +110 °C - Maximum operating pressure: 16 bar (1600 kPa)

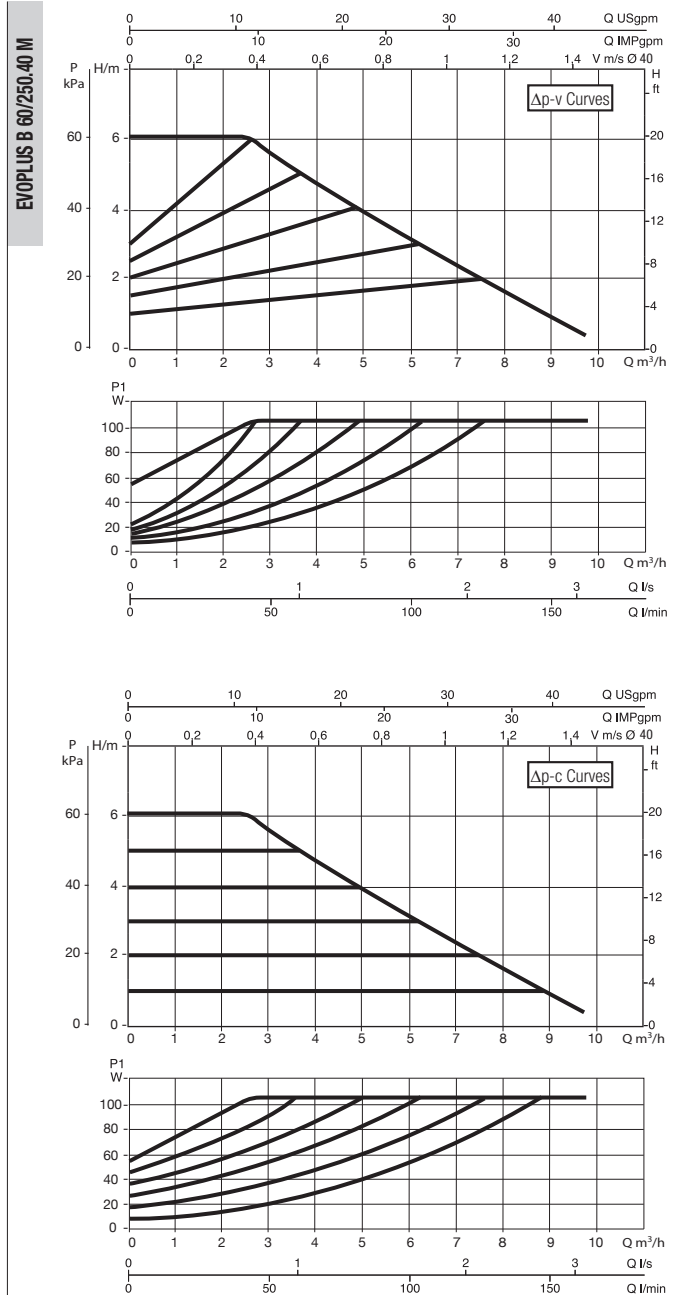
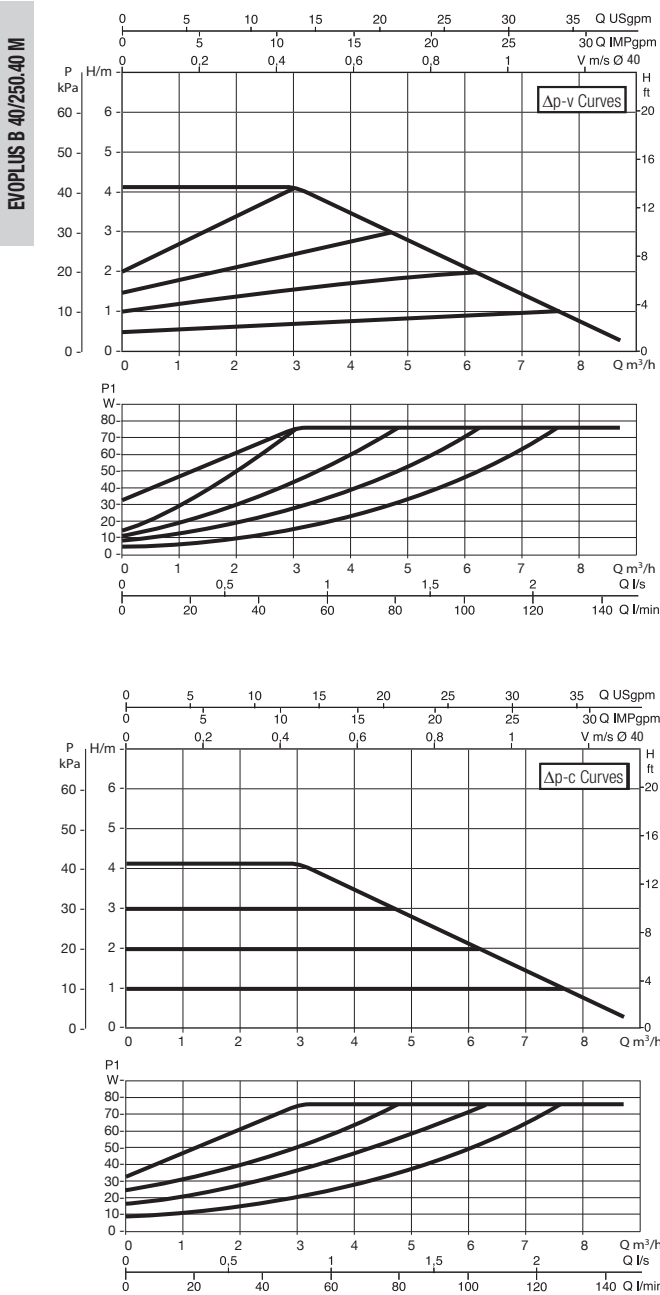

The curves are based on kinematic viscosity values = 1 mm²/s and density equal to 1000 kg/m³. Curve tolerance according to ISO 9906. Fixed speed curves available on the DNA.

MODEL	CENTRE DISTANCE mm	COUNTER FLANGES ON REQUEST	POWER INPUT 50/60 Hz	P1 MAX W	In A	EEI *	MINIMUM SUCTION PRESSURE			WEIGHT kg
							t°	90 °	100°	
EVOPLUS B 40/250.40 M	250	DN 40 PN 10	220/240 V	75	0,55	EEI ≤ 0,21	m.c.w.	20	25	7,5
EVOPLUS B 60/250.40 M	250	DN 40 PN 10	220/240 V	105	0,75	EEI ≤ 0,21	m.c.w.	20	25	7,5

The parameter of reference for the more efficient circulators is EEI ≥ 0,20.

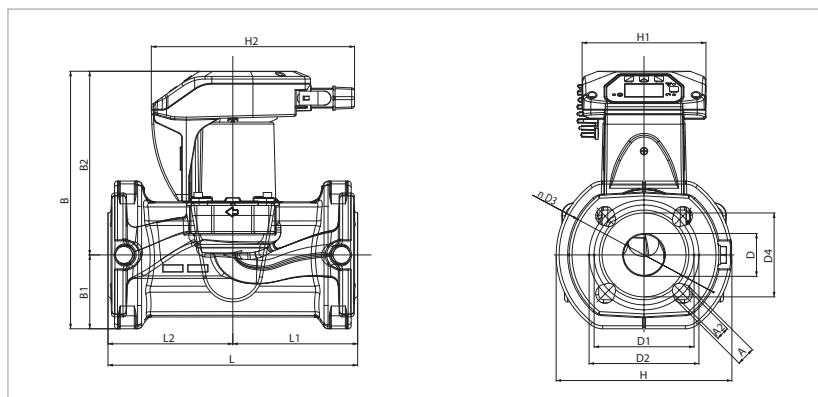

L	L1	L2	A	A2	B	B1	B2
250	125	125	19	14	258	74	184

D	D1	D2	D3	D4	H	H1	H2
43	100	110	150	84	176	124	204

EVOPLUS SMALL - ELECTRONIC CIRCULATORS FOR HEATING AND AIR CONDITIONING SYSTEMS - SINGLE, FLANGED

Pumped liquid temperature range: from -10 °C to +110 °C - Maximum operating pressure: 16 bar (1600 kPa)

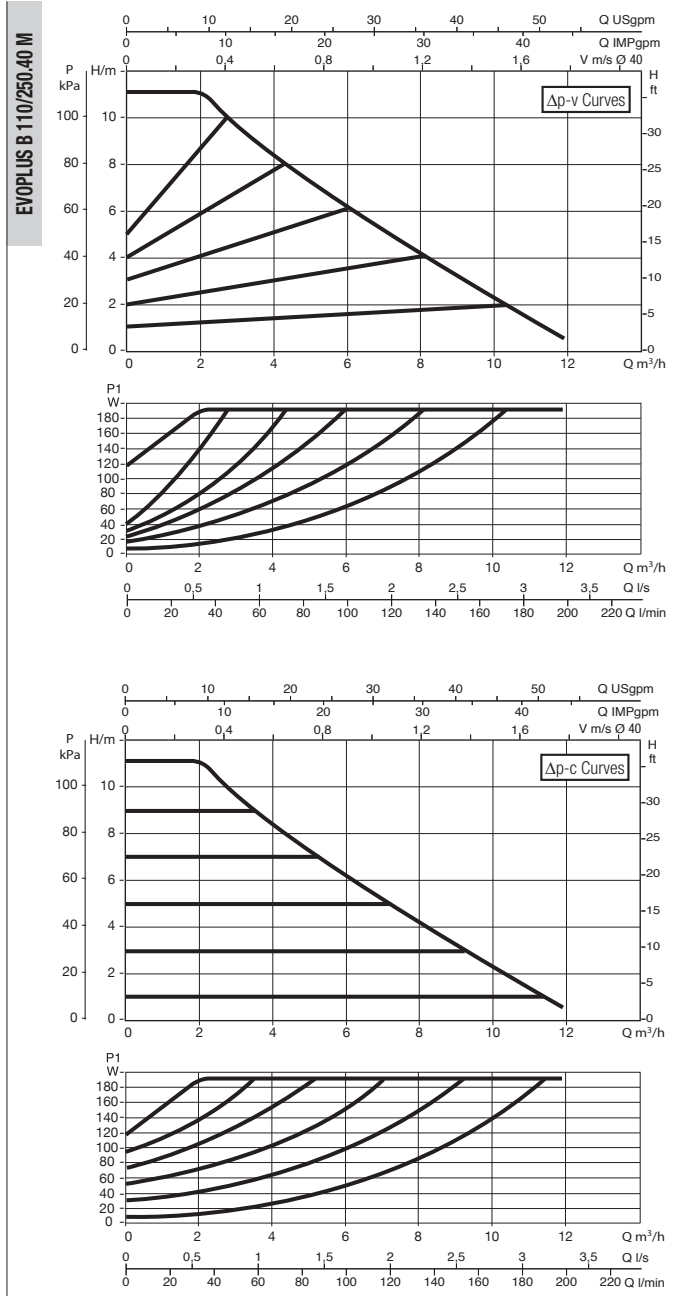
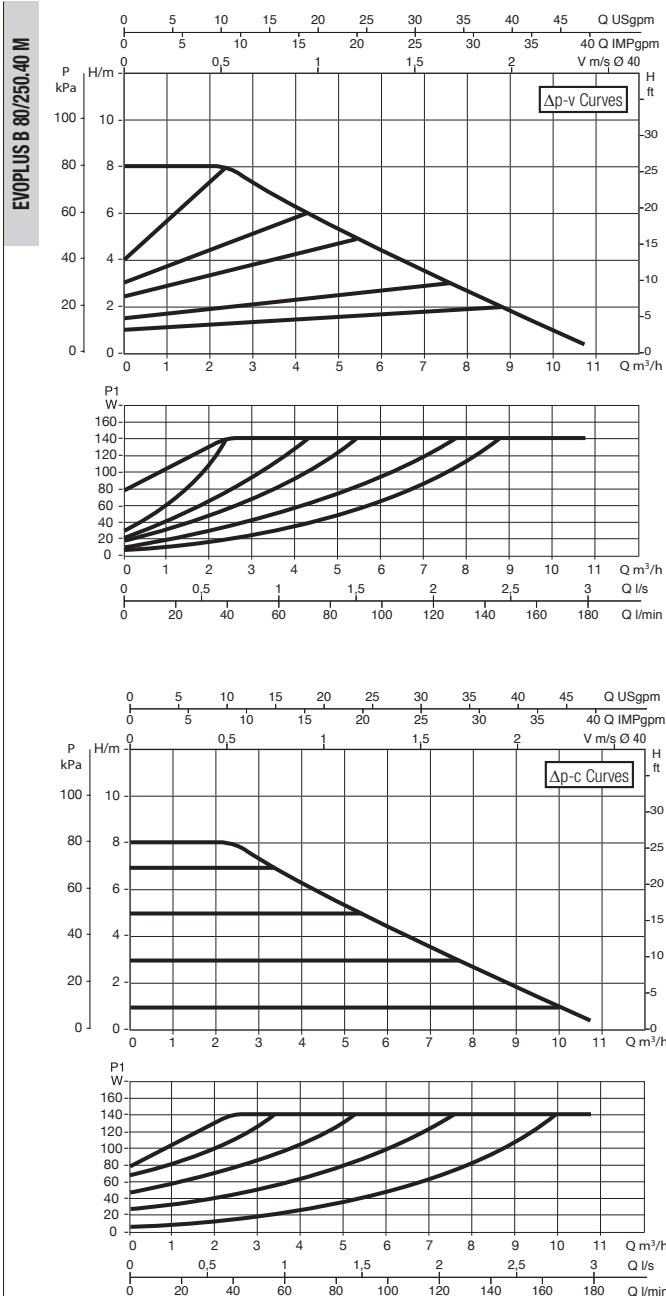

The curves are based on kinematic viscosity values = 1 mm²/s and density equal to 1000 kg/m³. Curve tolerance according to ISO 9906. Fixed speed curves available on the DNA.

MODEL	CENTRE DISTANCE mm	COUNTER FLANGES ON REQUEST	POWER INPUT 50/60 Hz	P1 MAX W	In A	EEI *	MINIMUM SUCTION PRESSURE			WEIGHT kg
							t°	90 °	100°	
EVOPLUS B 80/250.40 M	250	DN 40 PN 10	220/240 V	140	0,97	EEI ≤ 0,21	m.c.w.	20	25	7,5
EVOPLUS B 110/250.40 M	250	DN 40 PN 10	220/240 V	190	1,3	EEI ≤ 0,21	m.c.w.	20	25	7,5

The parameter of reference for the more efficient circulators is EEI ≥ 0,20.

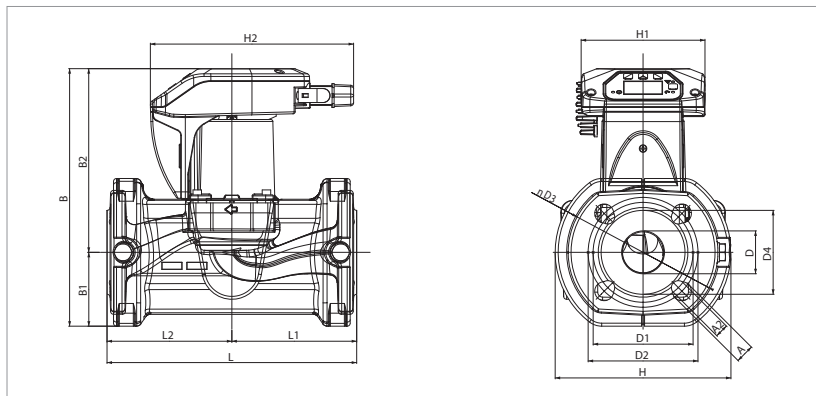

L	L1	L2	A	A2	B	B1	B2
250	125	125	19	14	258	74	184

D	D1	D2	D3	D4	H	H1	H2
43	100	110	150	84	176	124	204

EVOPLUS SMALL - ELECTRONIC CIRCULATORS FOR HEATING AND AIR CONDITIONING SYSTEMS - TWIN, FLANGED

Pumped liquid temperature range: from -10 °C to +110 °C - Maximum operating pressure: 16 bar (1600 kPa)

EVOPLUS D 40/220.32 M

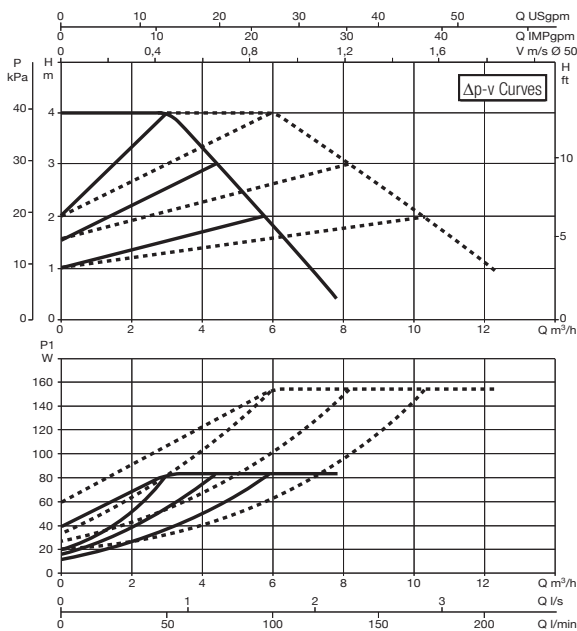

EVOPLUS D 60/220.32 M

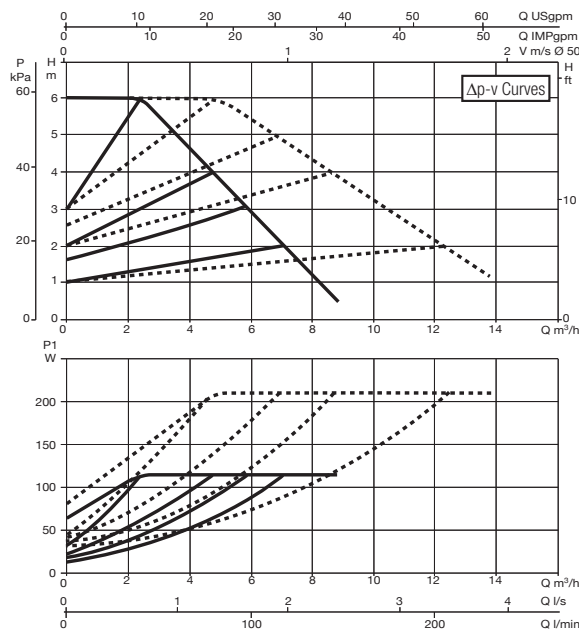

WET ROTOR ELECTRONIC CIRCULATORS

The curves are based on kinematic viscosity values = 1 mm²/s and density equal to 1000 kg/m³. Curve tolerance according to ISO 9906. Fixed speed curves available on the DNA.

MODEL	CENTRE DISTANCE mm	COUNTER FLANGES ON REQUEST	POWER INPUT 50/60 Hz	P1 MAX W	In A	EEI *	MINIMUM SUCTION PRESSURE			WEIGHT kg
							t°	90 °	100°	
EVOPLUS D 40/220.32 M	220	DN 32 PN 6	220/240 V	85	0,55	EEI ≤ 0,23	m.c.w.	20	25	13,5
EVOPLUS D 60/220.32 M	220	DN 32 PN 6	220/240 V	110	0,75	EEI ≤ 0,23	m.c.w.	20	25	13,5

The parameter of reference for the more efficient circulators is EEI ≥ 0,20.

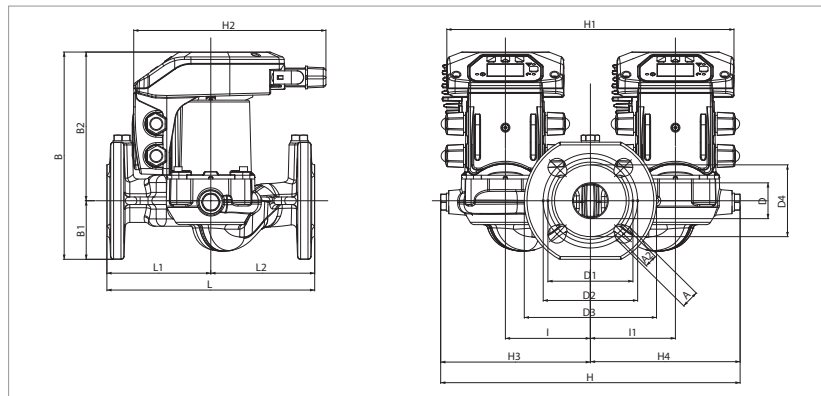

L	L1	L2	A	A2	B	B1	B2	D	D1
220	110	110	19	14	220	62	158	40	90

D2	D3	D4	I	I1	H	H1	H2	H3	H4
100	140	76	90	90	300	304	204	150	150

EVOPLUS SMALL - ELECTRONIC CIRCULATORS FOR HEATING AND AIR CONDITIONING SYSTEMS - TWIN, FLANGED

Pumped liquid temperature range: from -10 °C to +110 °C - Maximum operating pressure: 16 bar (1600 kPa)

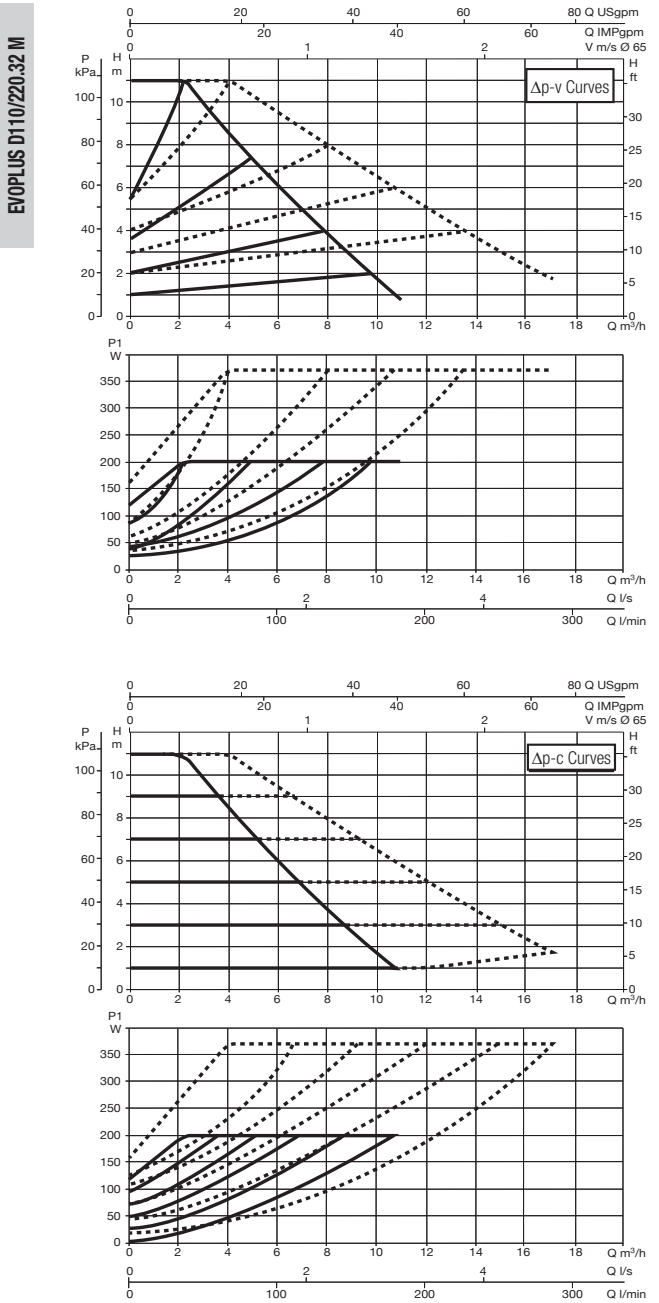
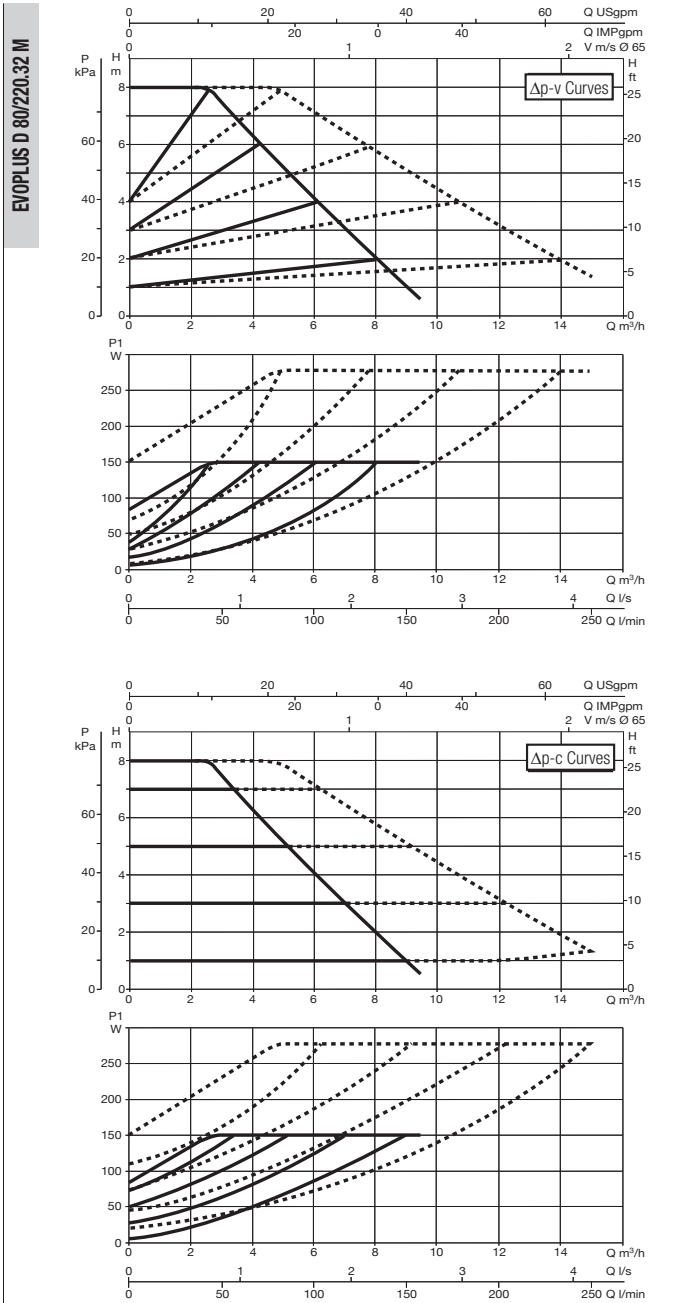

The curves are based on kinematic viscosity values = 1 mm²/s and density equal to 1000 kg/m³. Curve tolerance according to ISO 9906. Fixed speed curves available on the DNA.

MODEL	CENTRE DISTANCE mm	COUNTER FLANGES ON REQUEST	POWER INPUT 50/60 Hz	P1 MAX W	In A	EEI *	MINIMUM SUCTION PRESSURE			WEIGHT kg
							t°	90 °	100°	
EVOPLUS D 80/220.32 M	220	DN 32 PN 6	220/240 V	150	0,95	EEI ≤ 0,23	m.c.w.	20	25	13,5
EVOPLUS D110/220.32 M	220	DN 32 PN 6	220/240 V	200	1,3	EEI ≤ 0,23	m.c.w.	20	25	13,5

The parameter of reference for the more efficient circulators is EEI ≥ 0,20.

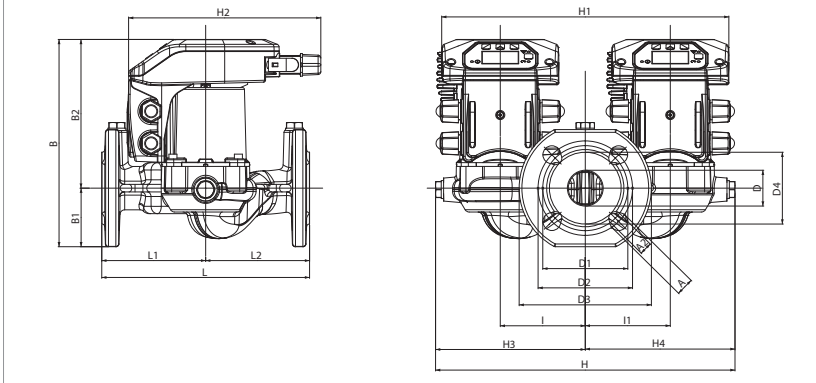

L	L1	L2	A	A2	B	B1	B2	D	D1
220	110	110	19	14	220	62	158	40	90

D2	D3	D4	I	I1	H	H1	H2	H3	H4
100	140	76	90	90	300	304	204	150	150



EVOPLUS SMALL - ELECTRONIC CIRCULATORS FOR HEATING AND AIR CONDITIONING SYSTEMS - TWIN, FLANGED

Pumped liquid temperature range: from -10 °C to +110 °C - Maximum operating pressure: 16 bar (1600 kPa)

EVOPLUS D 40/250.40 M

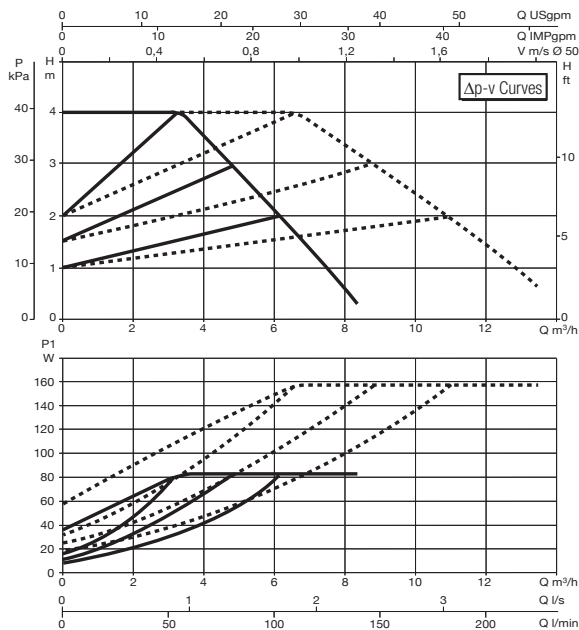

EVOPLUS D 60/250.40 M

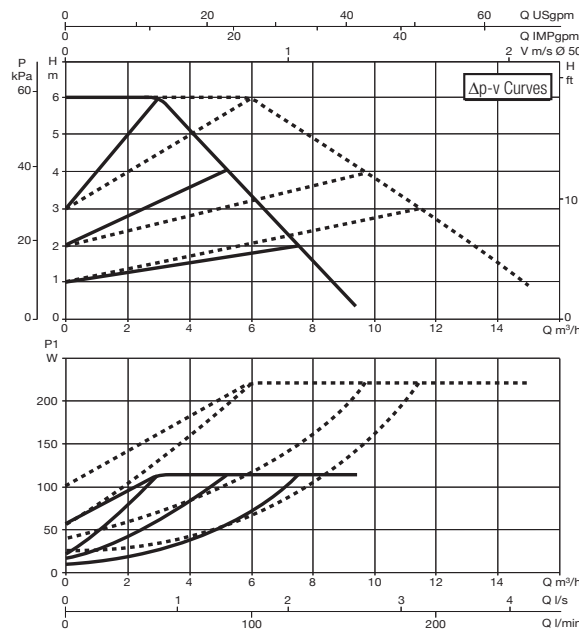

EVOPLUS D 40/250.40 M

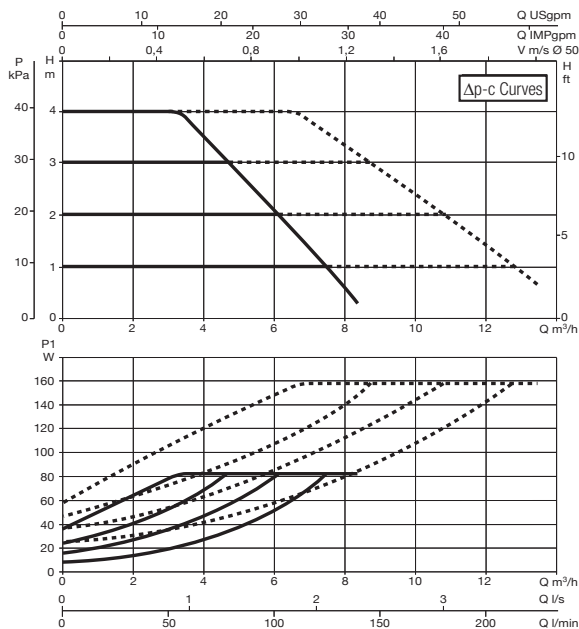

EVOPLUS D 60/250.40 M

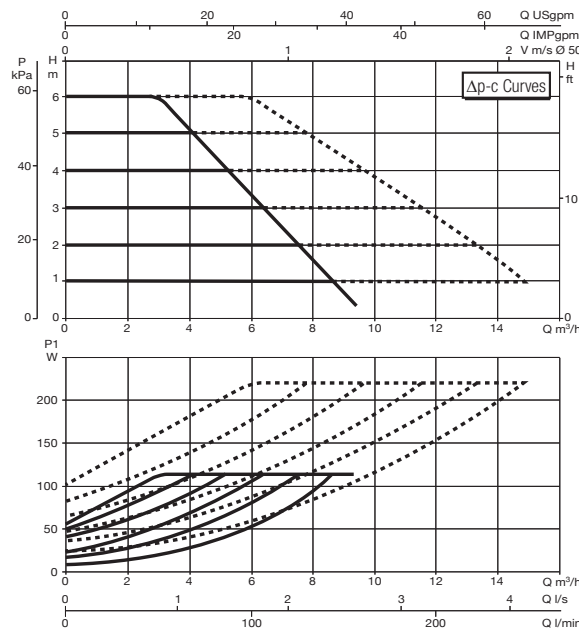

The curves are based on kinematic viscosity values = 1 mm²/s and density equal to 1000 kg/m³. Curve tolerance according to ISO 9906. Fixed speed curves available on the DNA.

MODEL	CENTRE DISTANCE mm	COUNTER FLANGES ON REQUEST	POWER INPUT 50/60 Hz	P1 MAX W	In A	EEI *	MINIMUM SUCTION PRESSURE			WEIGHT kg
							t°	90 °	100°	
EVOPLUS D 40/250.40 M	250	DN 40 PN 10	220/240 V	75	0,55	EEI ≤ 0,22	m.c.w.	20	25	14,2
EVOPLUS D 60/250.40 M	250	DN 40 PN 10	220/240 V	100	0,75	EEI ≤ 0,22	m.c.w.	20	25	14,2

The parameter of reference for the more efficient circulators is EEI ≥ 0,20.

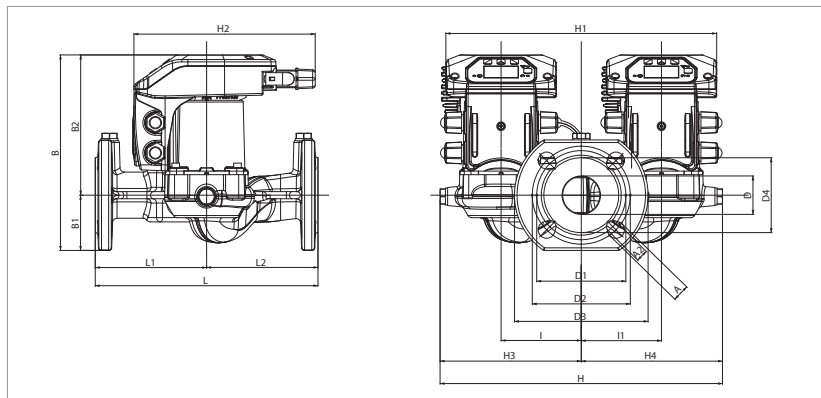

L	L1	L2	A	A2	B	B1	B2	D	D1
250	125	125	19	14	220	62	158	43	100

D2	D3	D4	I	I1	H	H1	H2	H3	H4
110	150	84	90	90	300	304	204	150	150

EVOPLUS SMALL - ELECTRONIC CIRCULATORS FOR HEATING AND AIR CONDITIONING SYSTEMS - TWIN, FLANGED

Pumped liquid temperature range: from -10 °C to +110 °C - Maximum operating pressure: 16 bar (1600 kPa)

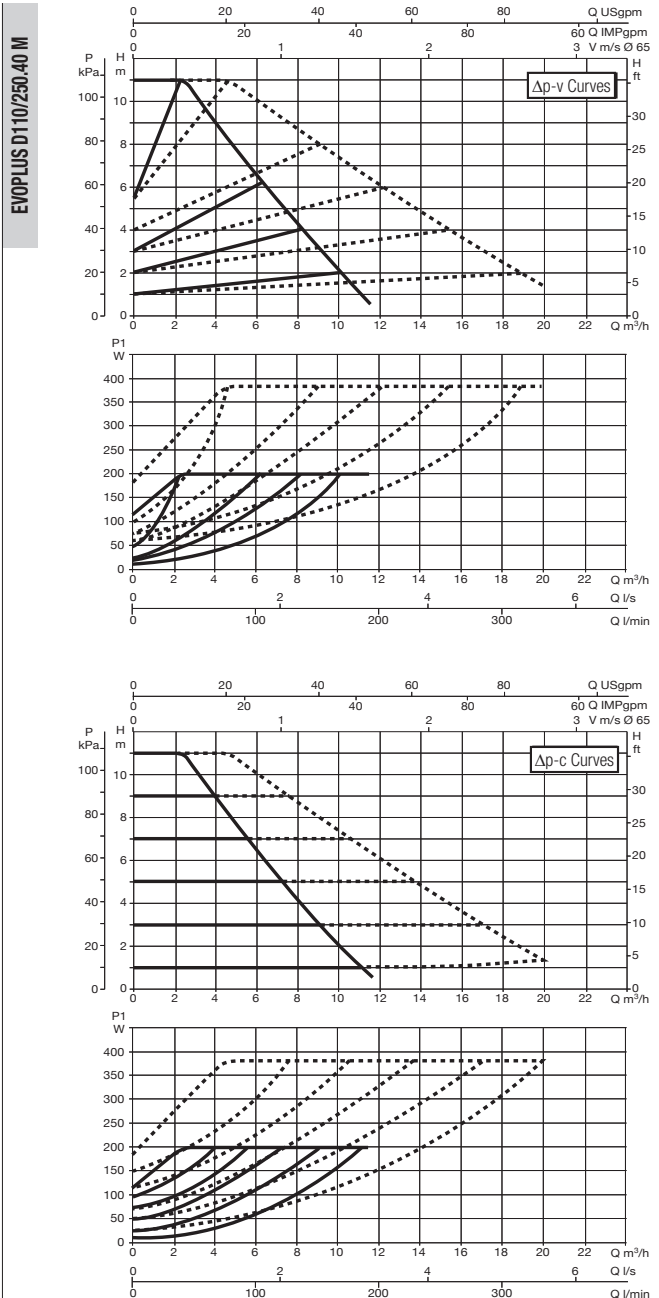
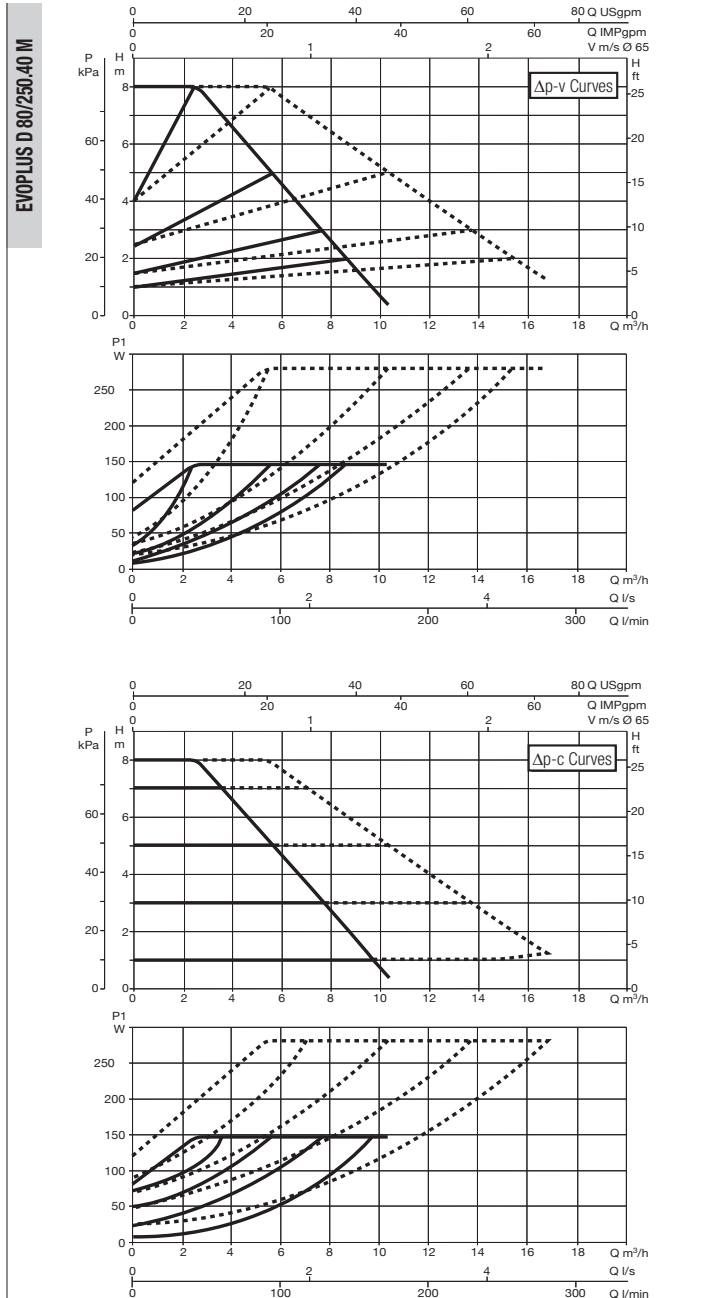

The curves are based on kinematic viscosity values = 1 mm²/s and density equal to 1000 kg/m³. Curve tolerance according to ISO 9906. Fixed speed curves available on the DNA.

MODEL	CENTRE DISTANCE mm	COUNTER FLANGES ON REQUEST	POWER INPUT 50/60 Hz	P1 MAX W	In A	EEI *	MINIMUM SUCTION PRESSURE			WEIGHT kg
							t°	90 °	100°	
EVOPLUS D 80/250.40 M	250	DN 40 PN 10	220/240 V	135	0,95	EEI ≤ 0,22	m.c.w.	20	25	14,2
EVOPLUS D110/250.40 M	250	DN 40 PN 10	220/240 V	190	1,3	EEI ≤ 0,22	m.c.w.	20	25	14,2

The parameter of reference for the more efficient circulators is EEI ≥ 0,20.

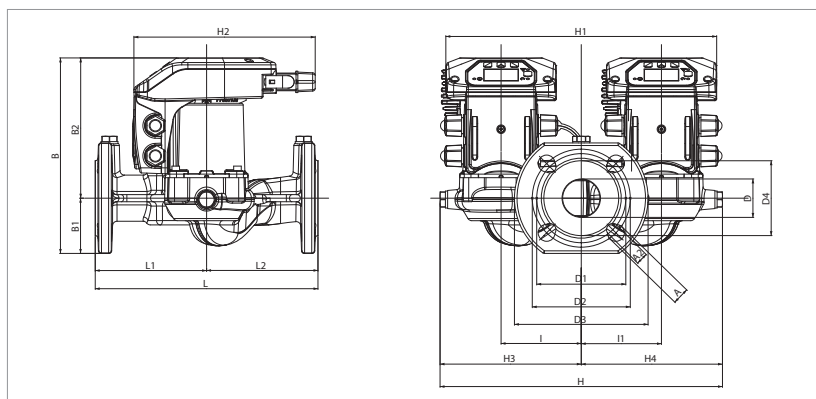

L	L1	L2	A	A2	B	B1	B2	D	D1
250	125	125	19	14	220	62	158	43	100

D2	D3	D4	I	I1	H	H1	H2	H3	H4
110	150	84	90	90	300	304	204	150	150

EVOPLUS SMALL SAN - ELECTRONIC CIRCULATORS FOR SANITARY WATER SYSTEMS - SINGLE, WITH UNIONS

Pumped liquid temperature range: from -10 °C to +110 °C - Maximum operating pressure: 16 bar (1600 kPa)

WET ROTOR ELECTRONIC CIRCULATORS

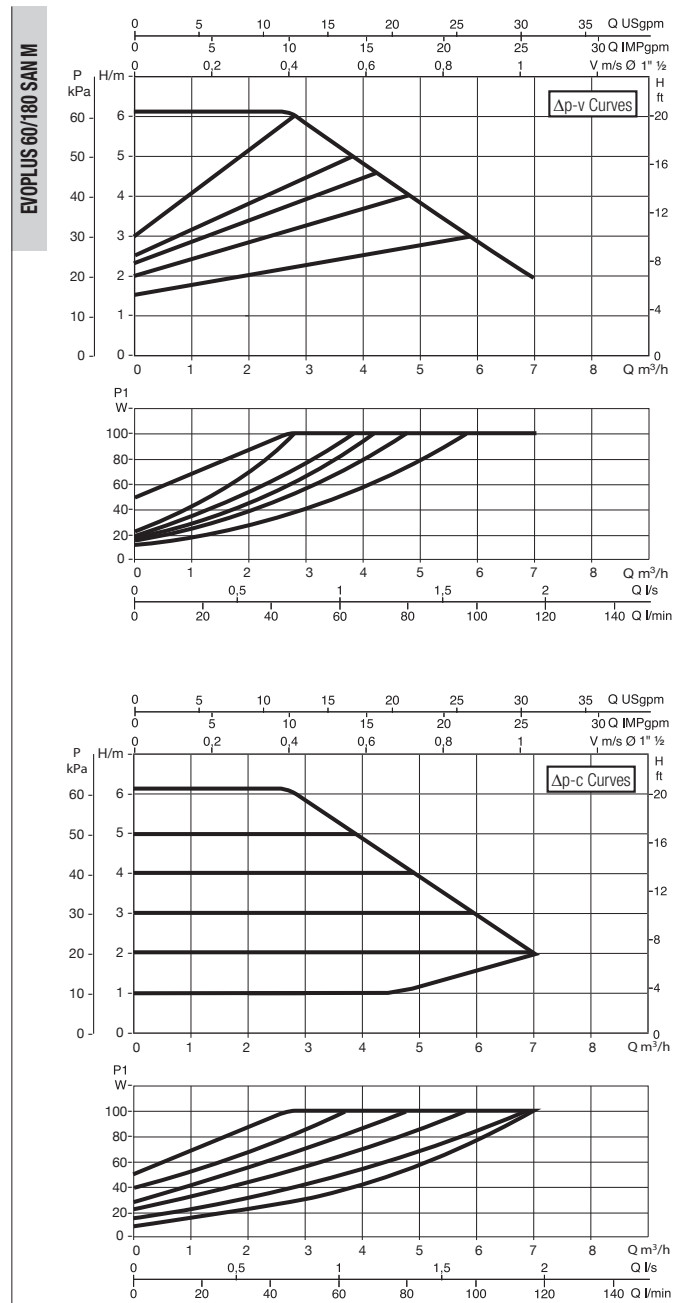
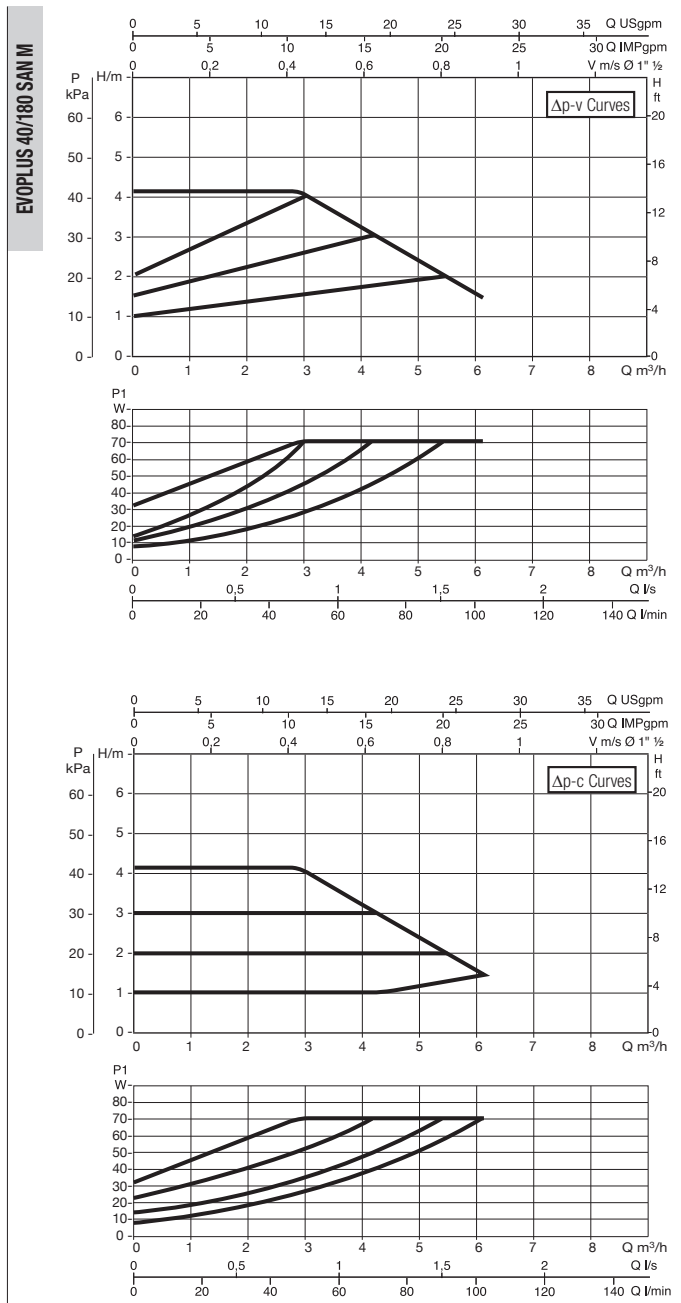

The curves are based on kinematic viscosity values = 1 mm²/s and density equal to 1000 kg/m³. Curve tolerance according to ISO 9906. Fixed speed curves available on the DNA.

MODEL	CENTRE DISTANCE mm	UNIONS ON REQUEST		POWER INPUT 50/60 Hz	P1 MAX W	I _n A	MINIMUM SUCTION PRESSURE			WEIGHT kg
		STANDARD	SPECIAL				t°	90°	100°	
EVOPLUS 40/180 SAN M	180	1" F	¾" F - 1¼" M	220/240 V	70	0,52	m.c.w.	20	25	4,5
EVOPLUS 60/180 SAN M	180	1" F	¾" F - 1¼" M	220/240 V	100	0,72	m.c.w.	20	25	4,5

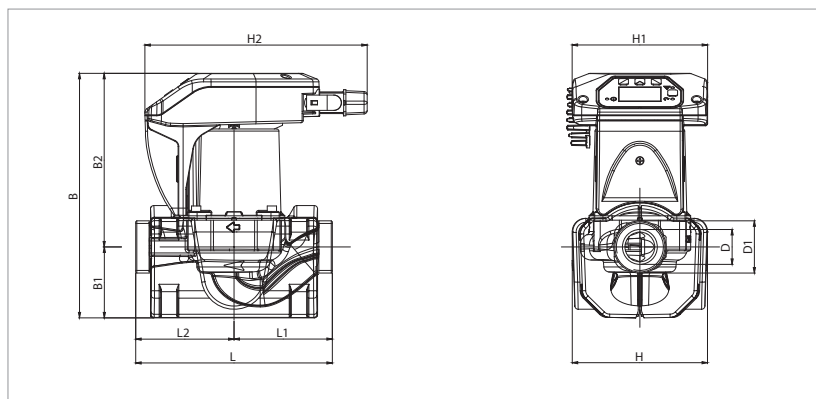

L	L1	L2	B	B1	B2	D	D1	H	H1	H2
180	90	90	224	65	159	32	1½"	124	124	204

EVOPLUS SMALL SAN - ELECTRONIC CIRCULATORS FOR SANITARY WATER SYSTEMS - SINGLE, WITH UNIONS

Pumped liquid temperature range: from -10 °C to +110 °C - Maximum operating pressure: 16 bar (1600 kPa)

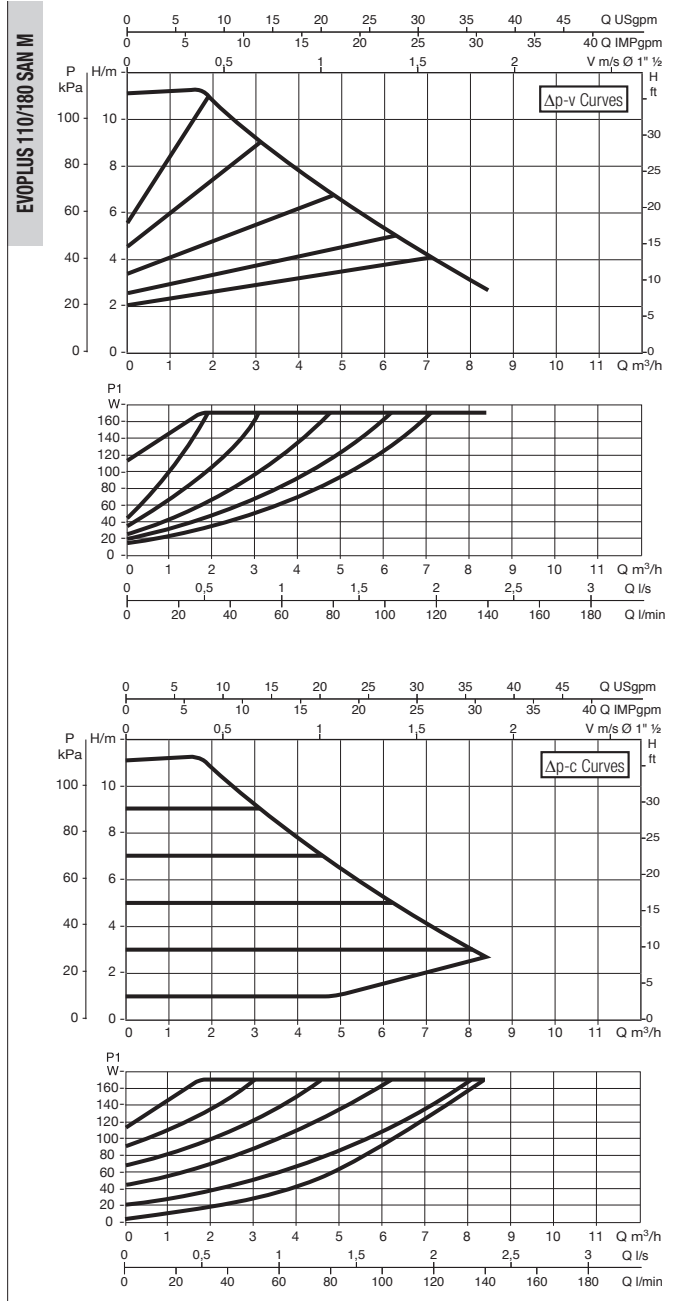
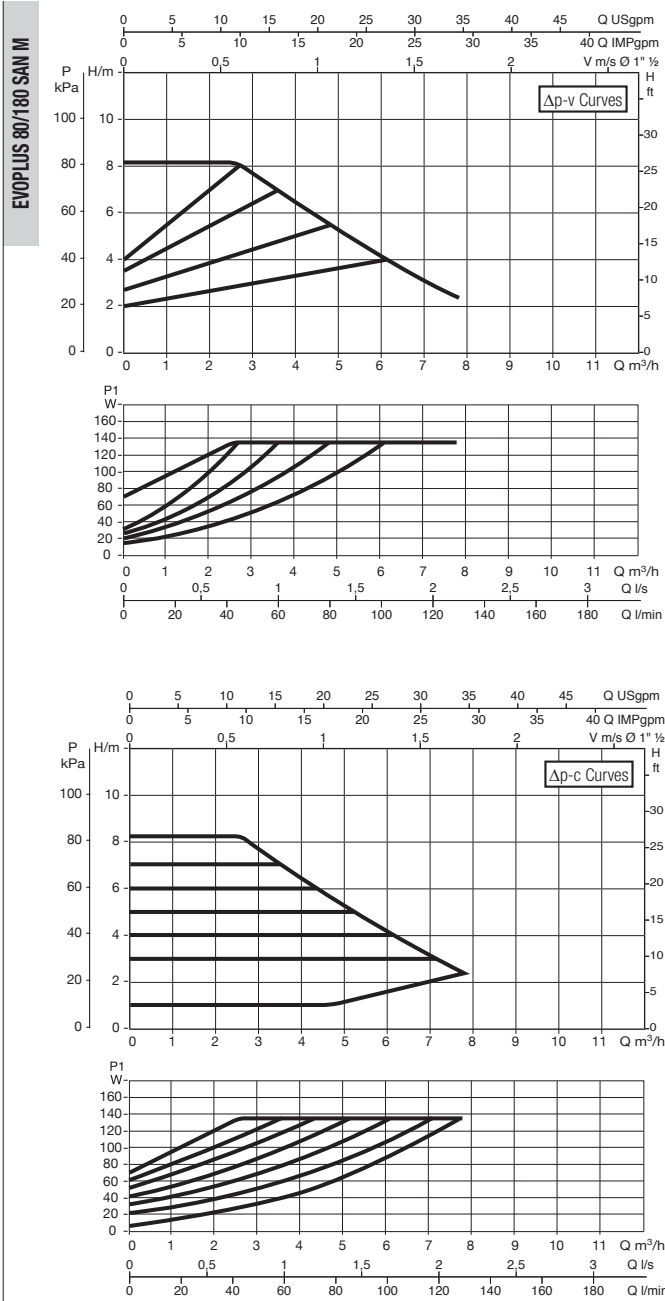

The curves are based on kinematic viscosity values = 1 mm²/s and density equal to 1000 kg/m³. Curve tolerance according to ISO 9906. Fixed speed curves available on the DNA.

MODEL	CENTRE DISTANCE mm	UNIONS ON REQUEST		POWER INPUT 50/60 Hz	P1 MAX W	In A	MINIMUM SUCTION PRESSURE			WEIGHT kg
		STANDARD	SPECIAL				t°	90 °	100°	
EVOPLUS 80/180 SAN M	180	1" F	¾" F - 1¼" M	220/240 V	135	0,95	m.c.w.	20	25	4,5
EVOPLUS 110/180 SAN M	180	1" F	¾" F - 1¼" M	220/240 V	170	1,16	m.c.w.	20	25	4,5

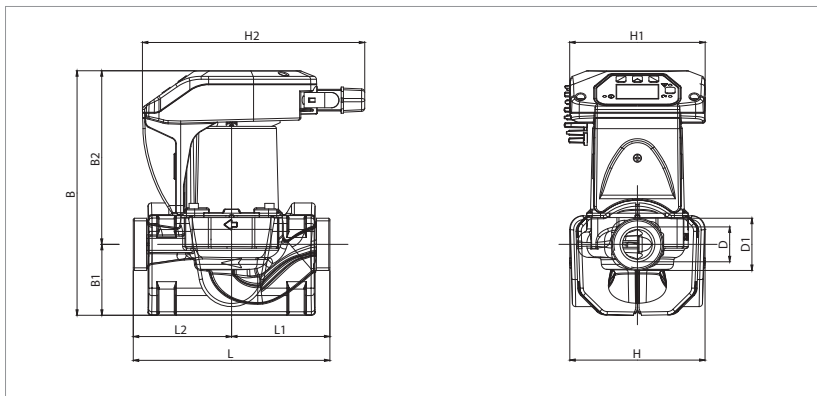

L	L1	L2	B	B1	B2	D	D1	H	H1	H2
180	90	90	224	65	159	32	1½"	124	124	204

EVOPLUS SMALL SAN - ELECTRONIC CIRCULATORS FOR SANITARY WATER SYSTEMS - SINGLE, FLANGED

Pumped liquid temperature range: from -10°C to +110 °C - Maximum operating pressure: 16 bar (1600 kPa)

EVOPLUS B 40/220.32 SAN M

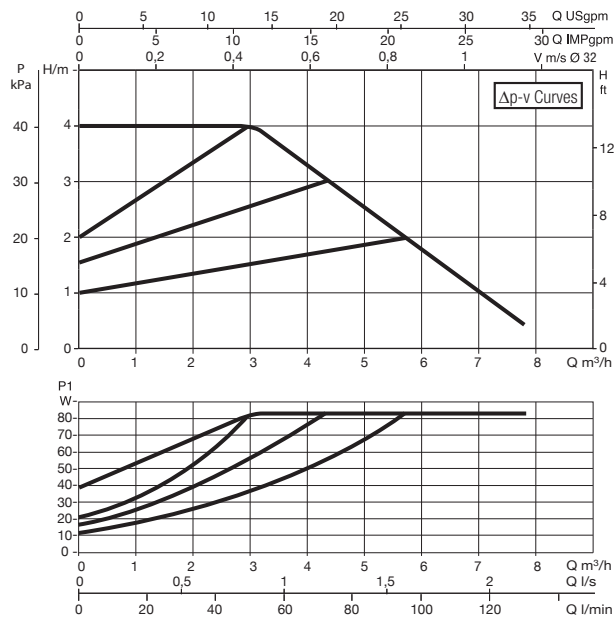

EVOPLUS B 60/220.32 SAN M

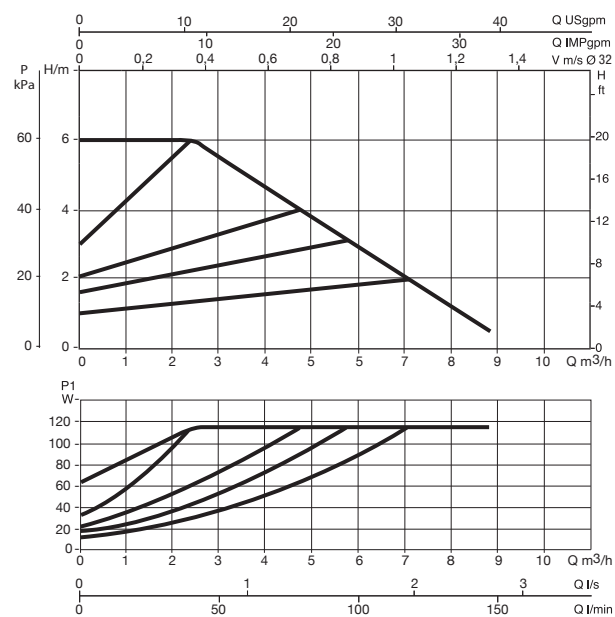

EVOPLUS B 40/220.32 SAN M

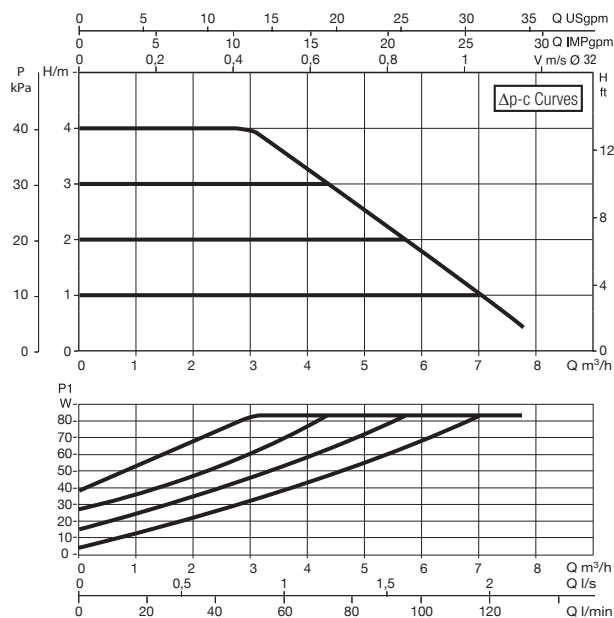

EVOPLUS B 60/220.32 SAN M

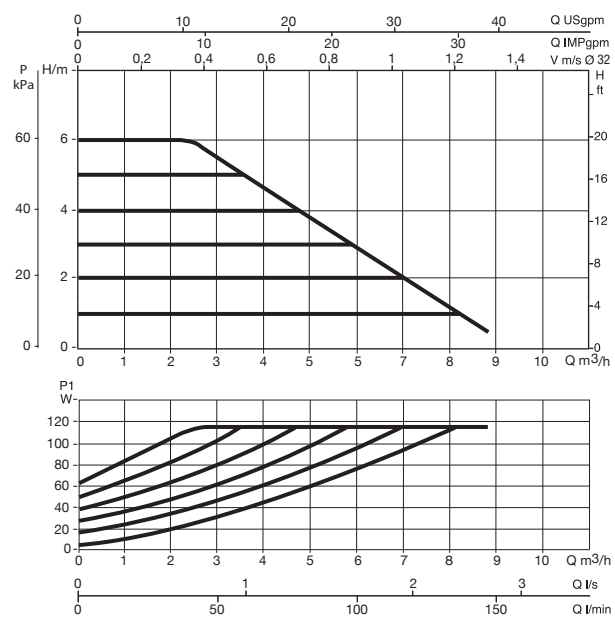

The curves are based on kinematic viscosity values = 1 mm²/s and density equal to 1000 kg/m³. Curve tolerance according to ISO 9906. Fixed speed curves available on the DNA.

MODEL	CENTRE DISTANCE mm	COUNTER FLANGES ON REQUEST	POWER INPUT 50/60 Hz	P1 MAX W	In A	MINIMUM SUCTION PRESSURE			WEIGHT kg
						t°	90°	100°	
EVOPLUS B 40/220.32 SAN M	220	DN 32 PN 6	220/240 V	85	0,55	m.c.w.	20	25	8,6
EVOPLUS B 60/220.32 SAN M	220	DN 32 PN 6	220/240 V	110	0,75	m.c.w.	20	25	8,6

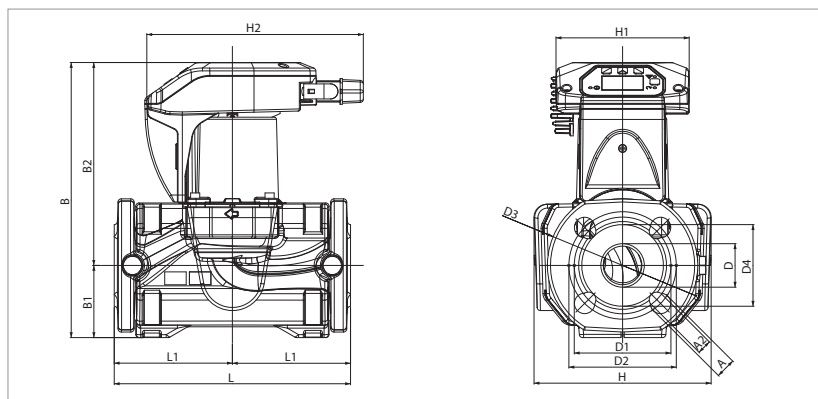

L	L1	L2	A	A2	B	B1	B2
220	110	110	19	14	256	67	189

D	D1	D2	D3	D4	H	H1	H2
40	90	100	140	76	165	124	204

EVOPLUS SMALL SAN - ELECTRONIC CIRCULATORS FOR SANITARY WATER SYSTEMS - SINGLE, FLANGED

Pumped liquid temperature range: from -10 °C to +110 °C - Maximum operating pressure: 16 bar (1600 kPa)

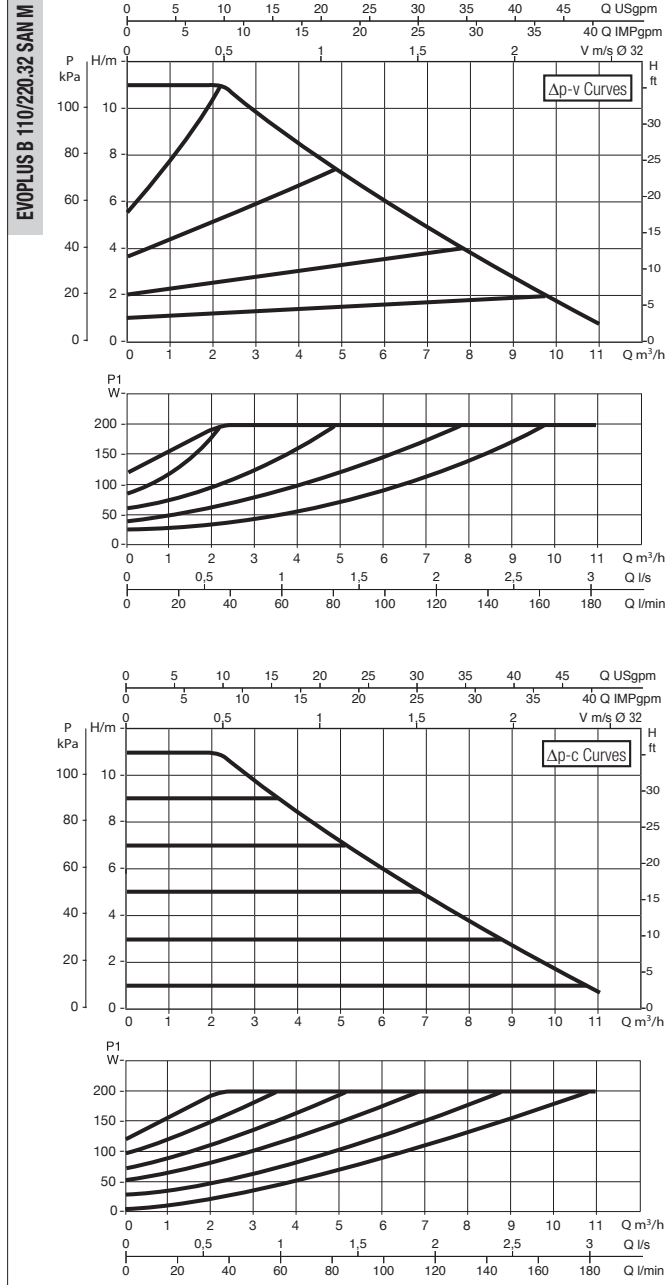
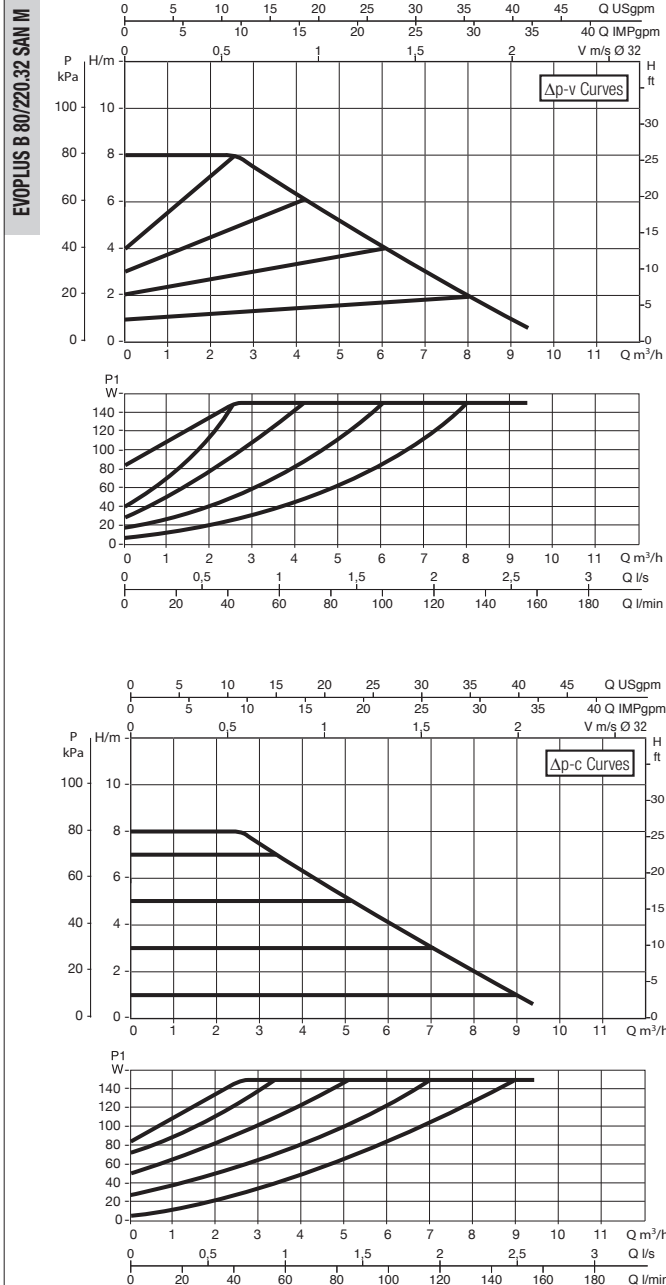

The curves are based on kinematic viscosity values = 1 mm²/s and density equal to 1000 kg/m³. Curve tolerance according to ISO 9906. Fixed speed curves available on the DNA.

MODEL	CENTRE DISTANCE mm	COUNTER FLANGES ON REQUEST	POWER INPUT 50/60 Hz	P1 MAX W	In A	MINIMUM SUCTION PRESSURE			WEIGHT kg
						t°	90°	100°	
EVOPLUS B 80/220.32 SAN M	220	DN 32 PN 6	220/240 V	150	0,97	m.c.w.	20	25	8,6
EVOPLUS B 110/220.32 SAN M	220	DN 32 PN 6	220/240 V	200	1,3	m.c.w.	20	25	8,6

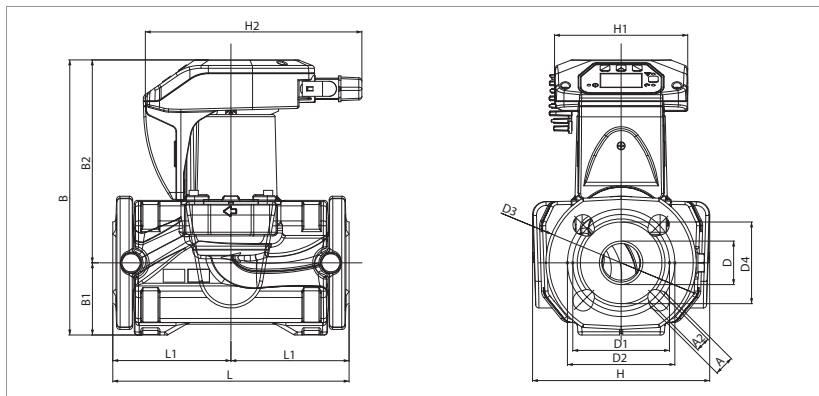

L	L1	L2	A	A2	B	B1	B2
220	110	110	19	14	256	67	189

D	D1	D2	D3	D4	H	H1	H2
40	90	100	140	76	165	124	204

EVOPLUS SMALL SAN - ELECTRONIC CIRCULATORS FOR SANITARY WATER SYSTEMS - SINGLE, FLANGED

Pumped liquid temperature range: from -10 °C to +110 °C - Maximum operating pressure: 16 bar (1600 kPa)

WET ROTOR ELECTRONIC CIRCULATORS

EVOPLUS B 40/250.40 SAN M

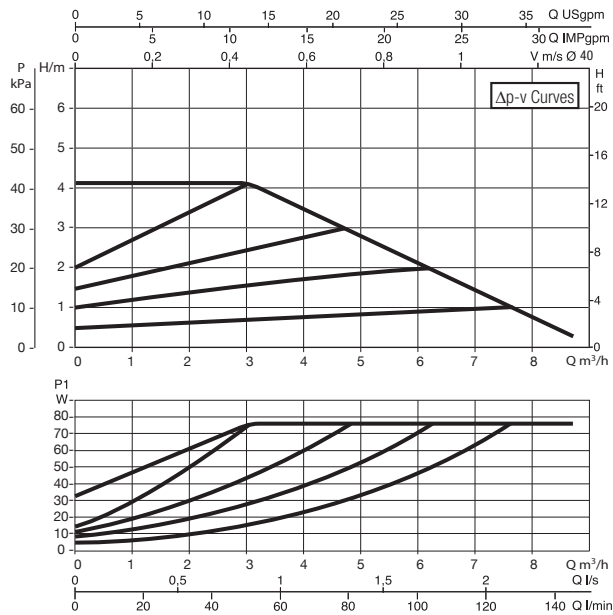

EVOPLUS B 60/250.40 SAN M

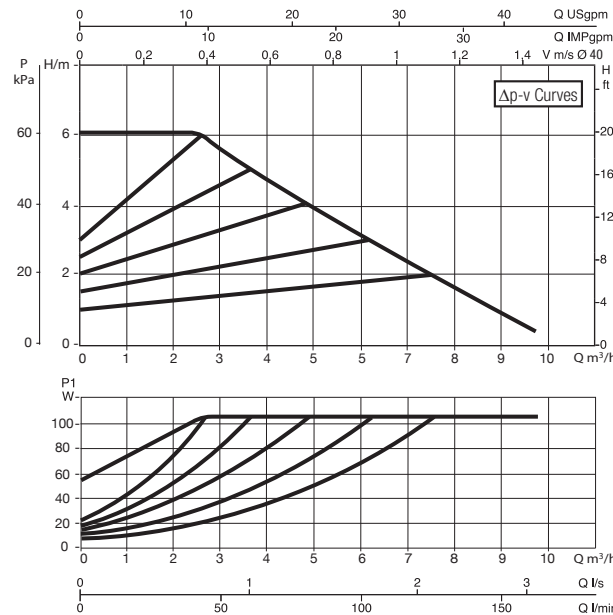

EVOPLUS B 40/250.40 SAN M

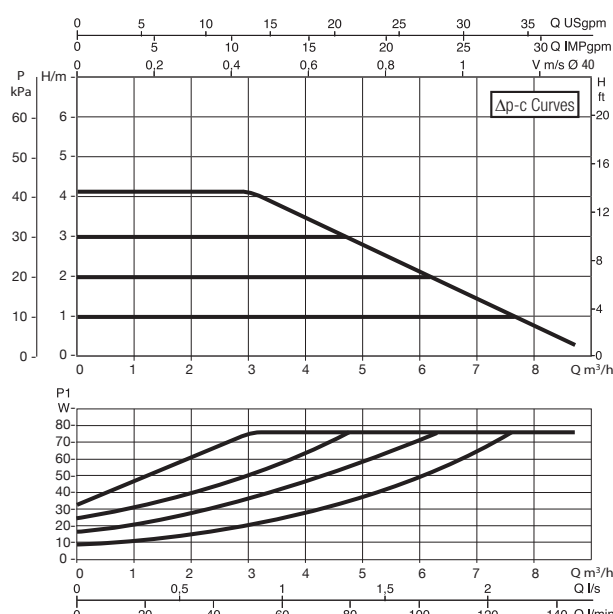

EVOPLUS B 60/250.40 SAN M

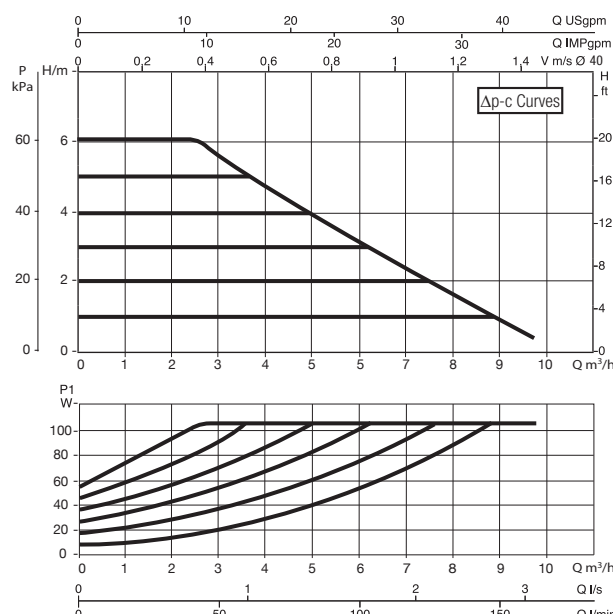

The curves are based on kinematic viscosity values = 1 mm²/s and density equal to 1000 kg/m³. Curve tolerance according to ISO 9906. Fixed speed curves available on the DNA.

MODEL	CENTRE DISTANCE mm	COUNTER FLANGES ON REQUEST	POWER INPUT 50/60 Hz	P1 MAX W	In A	MINIMUM SUCTION PRESSURE			WEIGHT kg
						t°	90°	100°	
EVOPLUS B 40/250.40 SAN M	250	DN 40 PN 10	220/240 V	75	0,55	m.c.w.	20	25	9,3
EVOPLUS B 60/250.40 SAN M	250	DN 40 PN 10	220/240 V	105	0,75	m.c.w.	20	25	9,3

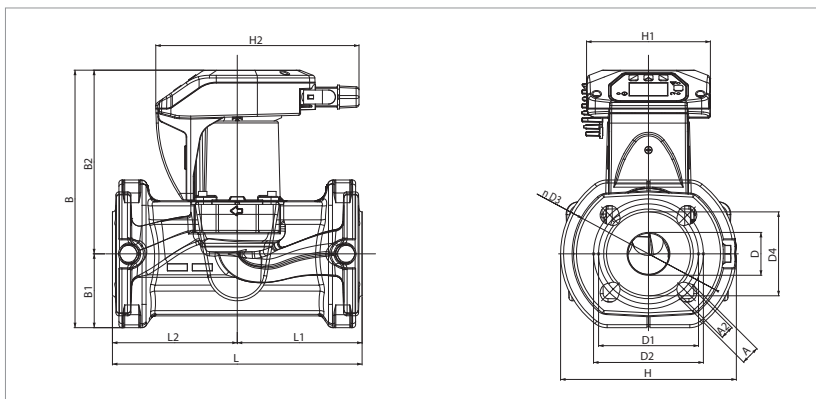

L	L1	L2	A	A2	B	B1	B2
250	125	125	19	14	258	74	184

D	D1	D2	D3	D4	H	H1	H2
43	100	110	150	84	176	124	204

EVOPLUS SMALL SAN - ELECTRONIC CIRCULATORS FOR SANITARY WATER SYSTEMS - SINGLE, FLANGED

Pumped liquid temperature range: from -10 °C to +110 °C - Maximum operating pressure: 16 bar (1600 kPa)

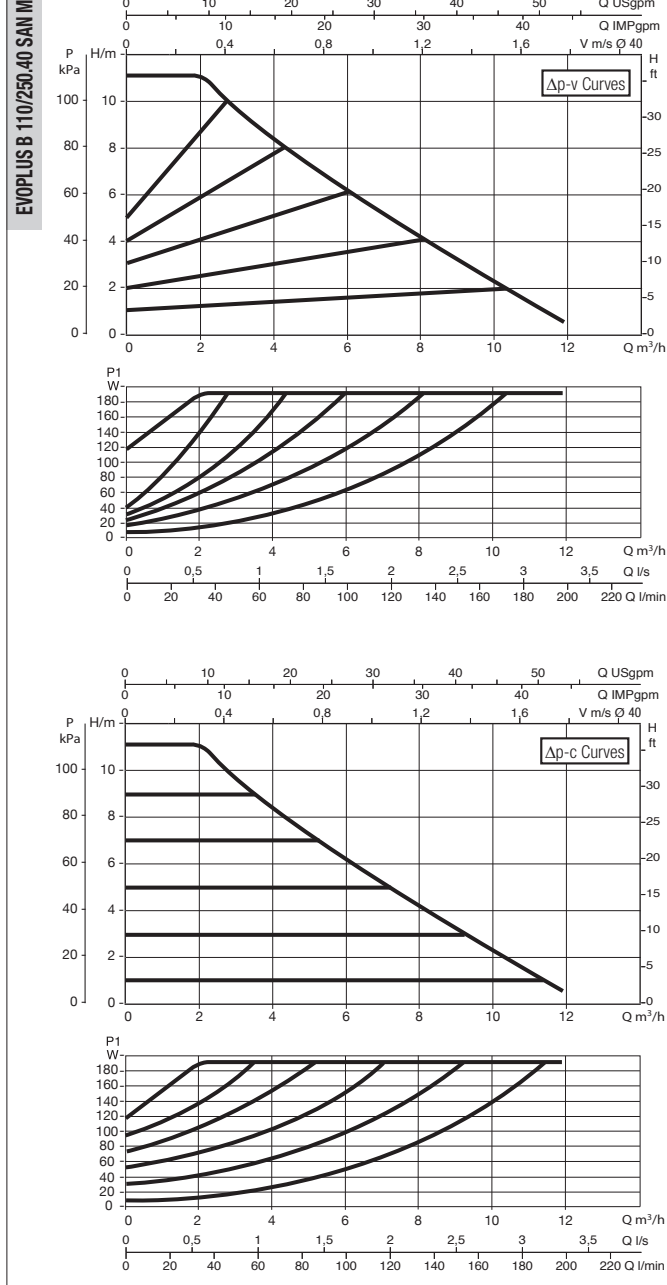
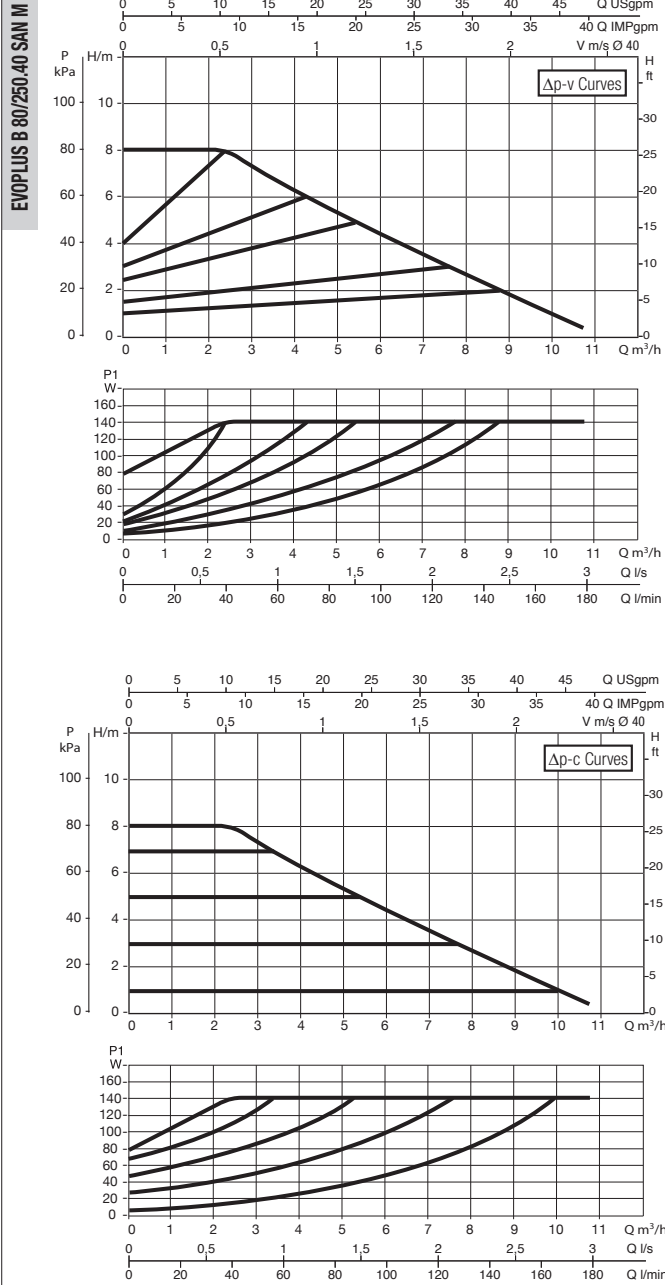

The curves are based on kinematic viscosity values = 1 mm²/s and density equal to 1000 kg/m³. Curve tolerance according to ISO 9906. Fixed speed curves available on the DNA.

MODEL	CENTRE DISTANCE mm	COUNTER FLANGES ON REQUEST	POWER INPUT 50/60 Hz	P1 MAX W	In A	MINIMUM SUCTION PRESSURE			WEIGHT kg
						t°	90 °	100°	
EVOPLUS B 80/250.40 SAN M	250	DN 40 PN 10	220/240 V	140	0,97	m.c.w.	20	25	9,3
EVOPLUS B 110/250.40 SAN M	250	DN 40 PN 10	220/240 V	190	1,3	m.c.w.	20	25	9,3

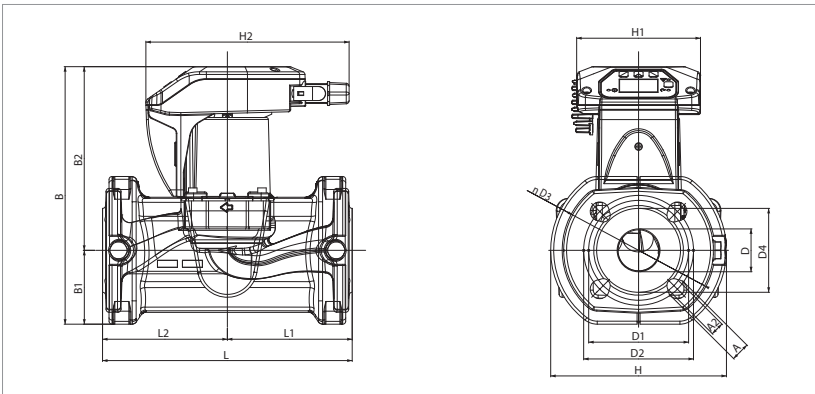

L	L1	L2	A	A2	B	B1	B2
250	125	125	19	14	258	74	184

D	D1	D2	D3	D4	H	H1	H2
43	100	110	150	84	176	124	204



EVOPLUS / EVOPLUS SAN

WET ROTOR ELECTRONIC CIRCULATORS



in line with European Directive
ErP 2009/125/EC (formerly EuP) of 2015

TECHNICAL DATA

Operating range: from 3 a 75.6 m³/h with head of up to 18 metres.

Pumped liquid temperature range: from -10 °C to +110 °C.

Pumped liquid: clean, free of solids and mineral oils, non-viscous, chemically neutral, with properties similar to water. (glycol max 30%).

Maximum operating pressure: 16 bar (1600 kPa).

Standard flanges: DN 32, DN 40, DN 50, DN 65, PN 6 / PN 10 / PN 16 (4 holes), DN 80 and DN 100, PN 6 (4 holes).

Maximum ambient temperature: + 40 °C.

Minimum suction pressure: the values are shown in the corresponding tables.

Special executions on request: DN 80, DN 100 PN 10 / PN 16 (8 holes).

Accessories (Counter flanges): PN 10 DN 32 - DN 40 - DN 50 - DN 65
PN 6 DN 80 - DN 100.

Electromagnetic compatibility: EVOPLUS circulator comply with EN 61800-3 standard, category C2, as far as electromagnetic compatibility. Electromagnetic emissions - Residential environment (containment measures might be required in some cases). Conducted emissions - Residential environment (containment measures might be required in some cases).

APPLICATIONS

EVOPLUS circulation electronic pumps can be used in heating, ventilation, and air conditioning systems for residential and commercial buildings, like:

- Large residential buildings
- Private and public hospitals
- Real estate buildings
- Condominiums and small apartment buildings
- Schools
- Homes
- Office buildings

All the models are available both in the single and twin version.

Bronze pump execution for the recirculation of sanitary water, available in single version with DN 32, DN 40, DN 50 and DN 65 flanged ports.

Supplied as a standard ready for control using 0-10 V or PWM external signal, and for the connection to ModBus management systems (LonBus with appropriate communication module available as optional).

HEATING SYSTEM APPLICATIONS

The heating required for the different applications varies significantly during day and night, due to the external temperature, or the degree of occupancy inside the areas. To the above, one must add the different needs of the various environments, and the opening or closing of the various circuit branches of complex systems. Electronic wet rotor pumps ensure at all times, and virtually in all correctly sized systems, a sufficient level of energy, together with a quieter operation, and more comfort, together with an important reduction of operating costs.

AIR CONDITIONING APPLICATIONS

Unlike conventional electronic pumps, EVOPLUS electronic circulators can also be used in air conditioning systems where the temperature of the pumped liquid is lower than the room temperature. In these conditions, condensation tends to form on the outer surface of the circulator, which however does not affect the operation of the electronic and the mechanical components. The unit is designed and sized in such a way that it allows condensation to drain without damage to the construction components.

SANITARY RECIRCULATION APPLICATIONS

The SAN version, with bronze pump body, was specifically developed for the recirculation of sanitary water. With the constant temperature mode of operation, the temperature inside the recirculation piping is controlled without the need for thermostat valves, therefore optimizing comfort.

CONSTRUCTION FEATURES

Monobloc circulation pump consisting of the cast iron hydraulic section, and the wet rotor synchronous motor. Aluminium motor casing. Scroll type pump body featuring high hydraulic efficiency thanks to highly precise design and smooth internal surfaces. In-line suction and delivery ports.

The single version is supplied as standard with insulating casing, to avoid heat dispersion and/or the formation of condensation on the pump body.

For the twin version, the insulation must be provided by the installer. In any case, pay attention not to obstruct the condensation drainage ducts, to avoid impairing the operation of the circulator.

Technopolymer impeller, stainless steel motor shaft on ceramic bushings lubricated by the pumped liquid. Stainless steel rotor protection liner. Ceramic thrust ring, ethylene-propylene seal rings and carbon fibre composite stator liner. Asynchronous motor with permanent magnet rotor. The twin version features an automatic swing check valve incorporated in the delivery port, to avoid water recirculating through the unit when this is not running; in addition, a blank flange is also supplied as standard, to allow either of the two motors to be removed for servicing. The standard execution of the pump body is PN 16. DN 80 and DN 100 PN 16 (8 holes) also available on request.

Circulator protection class: IP X4D

Insulation class: F

Standard voltage: single-phase 220/240 V / 50/60 Hz

sound pressure value \leq 45 dB(A)

Product compliant with European Standards EN 61800-3 – EN 60335-1 – EN 60335-2-51

EVOPLUS / EVOPLUS SAN

WET ROTOR ELECTRONIC CIRCULATORS

EVOPLUS CONSTRUCTION CHARACTERISTICS COLLECTIVE SYSTEMS (ELECTRONIC DEVICE)*

EVOPLUS circulators are controlled by a latest generation NPT technology IGBT device, for better efficiency and strength. The specific features are:

- Sine-wave PWM modulation
- High carrier frequency to eliminate all audio band noise
- 2 dedicated 32 bit processors
one for driving the motor
one for the user interface, enabling to perform the following functions:
 - start/stop command
 - Economy command
 - 0-10 V analogue signal command
 - PWM signal command
 - 4-20 mA analogue signal command
 - ΔT temperature sensor signal command
 - connection to ModBus system management devices. Optional LonBus with appropriate module.
- Optimised "space vector" algorithm
- Presence/absence of system alarms
- Pump in operation notification

* Inputs only available if the associated function is active.

An intuitive and functional user interface guarantees ease of calibration by all users. The easy to read OLED display on the control panel, three simple navigation keys, an in-line cascade menu featuring the latest mobile technology trends, and a wide range of functions, mean that EVOPLUS circulators are truly revolutionary products. A reliable and sturdy construction, together with a modern and innovative design, complete the product, also in terms of aesthetic value.

MATERIALS

N.	PARTS	MATERIALS
1	PUMP BODY	CAST IRON 250 UNI ISO 185 - CTF BRONZE (for the SAN version)
4	IMPELLER	TECHNOPOLYMER
7A	MOTOR SHAFT	STAINLESS STEEL
7B	ROTOR	STAINLESS STEEL LINER
8	STATOR	-
10	MOTOR CASING	DIE-CAST ALUMINIUM
127	SEAL RING	EPDM RUBBER
128	STATOR LINER	COMPOSITE AND CARBON FIBRE
130	CLOSING FLANGE	STAINLESS STEEL
131	THRUST RING SUPPORT	STAINLESS STEEL
132	BUSHINGS	ALUMINA

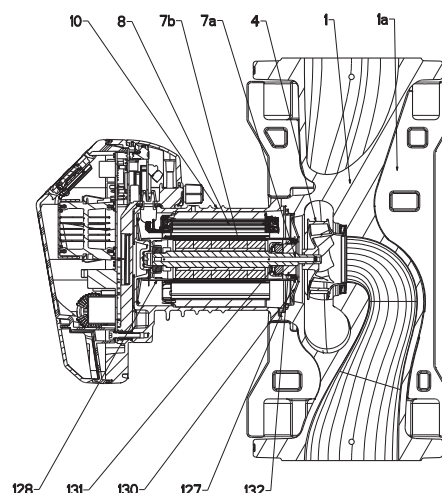

- Legend: (example)

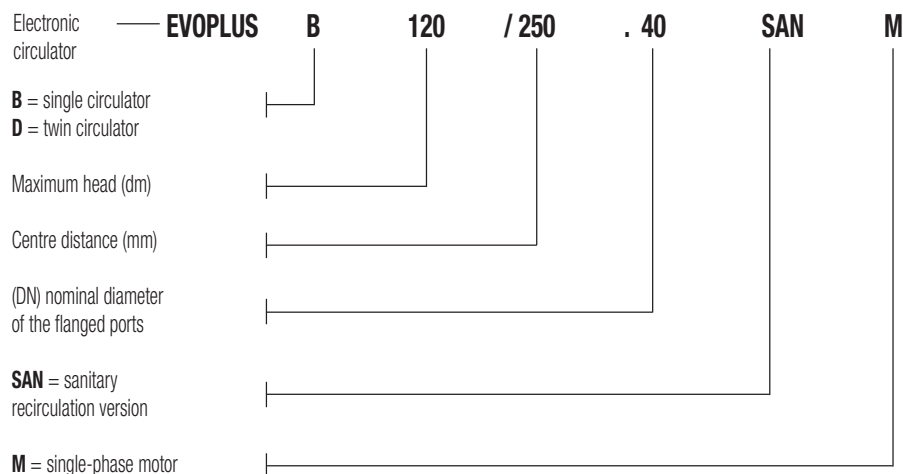

MODES OF OPERATION

All the functions listed below can be consulted by the users (including less experienced ones) by simply scrolling through the menu. The calibration and the modification of the parameters are protected, and can only be completed by expert users. The factory settings of the EVOPLUS range are for proportional differential pressure control mode in the curve that ensures the best energy efficiency index (EEI).

1 - $\Delta P-v$ proportional differential pressure adjustment mode

With $\Delta P-v$ adjustment mode, with the variation of the flow rate, the value of the delivery of the head also varies in a linear manner, from H_{setp} to $H_{setp}/2$.

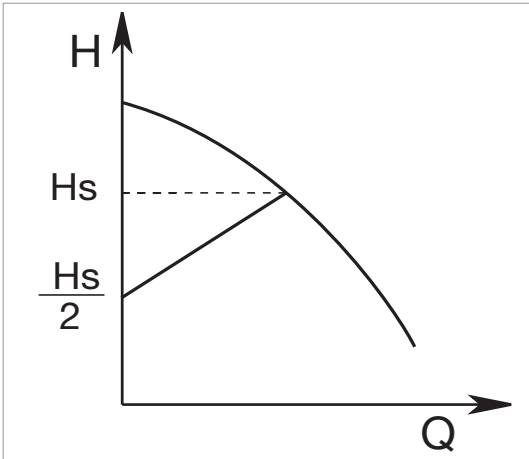

This adjustment is particularly indicated for the following systems:

a. Two-pipe heating systems with thermostat valves and with:

- head greater than 4 metres;
- very long circuit piping;
- valves with wide operating range;
- differential pressure regulators;
- high pressure drops in those parts of the system carrying the entirety of the water flow rate;
- low differential pressure.

b. Under-floor central heating systems with thermostatic valves and significant pressure drops in the boiler circuit.

c. Systems with primary circuit pumps with high pressure drops.

Example of set-up of the set-point with $\Delta P-v$

The following operating point is required:

$$Q = 6,5 \text{ m}^3/\text{h}$$

$$H = 6 \text{ m}$$

PROCEDURE:

1. In the graph, find the desired operating point, and then find the EVOPLUS curve closest to it (in this case the point lies precisely on the curve)
2. Follow the curve upwards until reaching the intersection with the limit curve of the circulator.
3. The head reading at this limit point is the set-point head that must be entered to obtain the desired operating point.

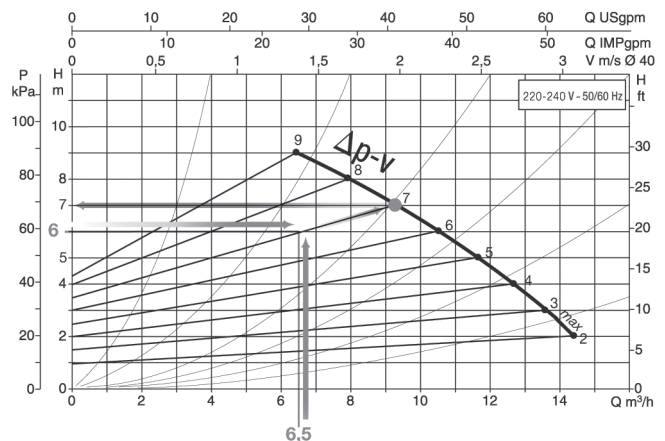

2 - $\Delta P-c$ constant differential pressure adjustment mode

The $\Delta P-c$ adjustment mode keeps the differential pressure of the system constantly at the H_{setp} value set, even in case of variation of the flow rate.

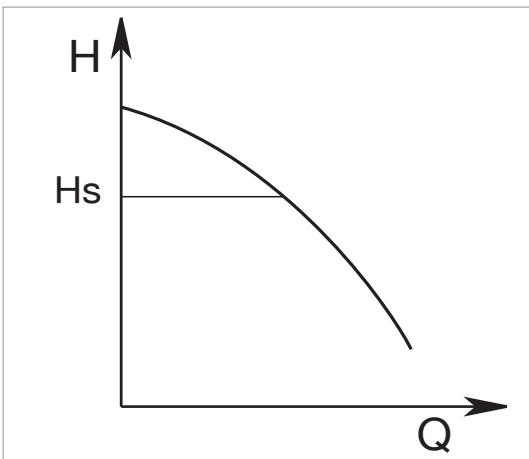

This adjustment is particularly indicated for the following systems:

a. Two-pipe heating systems with thermostat valves and with:

- head lower than 2 metres;
- natural circulation;
- low pressure drops in those parts of the system carrying the entirety of the water flow rate;
- high differential temperature (central heating).

b. underfloor heating systems with thermostat valves

c. single-pipe heating systems with thermostat valves and calibration valves

d. Systems with primary circuit pumps with low pressure drops.